

OPERATIONAL PLAN

For the Wasaga Beach Well Supply System



This Operational Plan is designed for the exclusive use of the system(s) specified in this Operational Plan.

This Operational Plan has been developed with OCWA's operating practices in mind and utilizing OCWA personnel to implement it.

Any use which a third party makes of this Operational Plan, or any part thereof, or any reliance on or decisions made based on information within it, is the responsibility of such third parties. OCWA accepts no responsibility for damages, if any, suffered by any third party as a result of decisions made or actions taken based on this Operational Plan or any part thereof.



OPERATIONAL PLAN
Wasaga Beach Well Supply System

QEMS Doc: OP-ToC
Issue Date: 2024-02-25
Pages: 1 of 1

TABLE OF CONTENTS

Reviewed by: Process & Compliance Technician | Approved by: Senior Operations Manager

- OP-01** OCWA's Quality & Environmental Management System (QEMS)
- OP-02** Quality & Environmental Management System Policy
- OP-03** Commitment & Endorsement of OCWA's QEMS & Operational Plan
 - OP-03A** Signed Commitment and Endorsement
- OP-04** Quality Management System Representative
- OP-05** Document and Records Control
 - OP-05A** Document and Records Control Locations
- OP-06** Drinking Water System
- OP-07** Risk Assessment
- OP-08** Risk Assessment Outcomes
 - OP-08A** Wasaga Beach Well Supply System- Summary of Risk Assessment Outcomes
- OP-09** Organizational Structure, Roles, Responsibilities & Authorities
 - OP-09A** Organizational Structure
- OP-10** Competencies
- OP-11** Personnel Coverage
- OP-12** Communications
- OP-13** Essential Supplies and Services
- OP-14** Review and Provision of Infrastructure
- OP-15** Infrastructure Maintenance, Rehabilitation and Renewal
- OP-16** Sampling, Testing and Monitoring
- OP-17** Measurement and Recording Equipment Calibration and Maintenance
- OP-18** Emergency Management
- OP-19** Internal QEMS Audits
- OP-20** Management Review
- OP-21** Continual Improvement

Schedule "C" MECP's Director's Directions *Minimum Requirements for Operational Plans*

 <p>Ontario Clean Water Agency</p>	<p style="text-align: center;">OPERATIONAL PLAN Wasaga Beach Well Supply System</p>	<p>QEMS Proc.: OP-01 Rev Date: 2024-08-19 Rev No: 2 Pages: 1 of 2</p>
QUALITY & ENVIRONMENTAL MANAGEMENT SYSTEM (QEMS)		
Reviewed by: Process & Compliance Technician	Approved by: Senior Operations Manager	

1. Purpose

To document OCWA's Quality & Environmental Management System (QEMS). This Operational Plan defines and documents the QEMS for the Wasaga Beach Well Supply System operated by the Ontario Clean Water Agency (OCWA). It sets out the OCWA's policies and procedures with respect to quality and environmental management in accordance with the requirements of the Province of Ontario's Drinking Water Quality Management Standard (DWQMS).

2. Definitions

Drinking Water Quality Management Standard (DWQMS) – has the same meaning as Quality Management Standard for Drinking Water Systems approved under section 21 of the Safe Drinking Water Act (SDWA).

Operational Plan – means the operational plan required by the Director's Direction.

Quality & Environmental Management System (QEMS) – a system to:

- a) Establish policy and objectives, and to achieve those objectives; and
- b) Direct and control an organization with regard to quality.

Ministry - means the Ontario government ministry responsible for the administration of the SDWA.

3. Procedure

3.1 The Wasaga Beach Well Supply System is owned by the Corporation of the Town of Wasaga Beach. OCWA is the contracted Operating Authority for the Wasaga Beach Well Supply System.

3.2 OCWA's Quality & Environmental Management System (QEMS) is structured and documented with the purpose of:

1. Establishing policy and objectives with respect to the effective management and operation of water/wastewater facilities;
2. Understanding and controlling the risks associated with the facility's activities and processes;
3. Achieving continual improvement of the QEMS and the facility's performance.

3.3 The Operational Plan for the facility listed above fulfils the requirements of the Ministry's DWQMS. The 21 QEMS Procedures within this Operational Plan align with the 21 elements of the DWQMS.

4. Related Documents

Ontario's Drinking Water Quality Management Standard, as amended from time to time
All QEMS Procedures and Documents referenced in this Operational Plan



OPERATIONAL PLAN
Wasaga Beach Well Supply System

QEMS Proc.: OP-01
Rev Date: 2024-08-19
Rev No: 2
Pages: 2 of 2

QUALITY & ENVIRONMENTAL MANAGEMENT SYSTEM (QEMS)

Reviewed by: Process & Compliance Technician

Approved by: Senior Operations Manager

5. Revision History

Date	Revision #	Reason for Revision
2018-05-25	0	Procedure issued – Information within OP-01 was originally set out in the Main body of OCWA’s Operational Plan (last revision #7 dated 2016-06-22). New Purpose, Definitions, Procedure, Related Documents and separate Revision History sections. Addition of new wording (s. 3.3) to clarify that the OCWA’s Operational Plan now aligns with the 21 elements of the DWQMS.
2022-03-25	1	Any reference to the MOECC was updated to MECP, as identified in the 2022 External System Audit
2024-08-19	2	Procedure updated. Definition of DWQMS, added definition of Ministry as the Ontario government ministry responsible for drinking water and environmental legislation to alleviate need for future revisions if/when the Ministry experiences name changes, added “as amended from time to time directly following reference to Ontario’s DWQMS to point to the most current version of the document, removed watermark.



Ontario Clean Water Agency

OPERATIONAL PLAN

Wasaga Beach Well Supply System

QEMS Proc.: OP-02
Rev Date: 2024-08-19
Rev No: 2
Pages: 1 of 2

QUALITY & ENVIRONMENTAL MANAGEMENT SYSTEM (QEMS) POLICY

Reviewed by: Process & Compliance Technician

Approved by: Senior Operations Manager

1. Purpose

To document a QEMS Policy that provides the foundation for OCWA's Quality & Environmental Management System.

2. Definitions

Quality Management System Policy – means the policy described in Element 2 developed for the Subject System or Subject Systems

3. Procedure

3.1 The Ontario Clean Water Agency, its Board of Directors, Officers and entire staff are committed to the principles and objectives set out in our QEMS Policy.

OCWA's Policy is to:

- Deliver safe water and wastewater services that protect public health, the environment, and the sustainability of communities.
- Comply with applicable legislation and regulations.
- Promote client, consumer and stakeholder confidence through service excellence, effective communications and reporting.
- Train staff on their QEMS responsibilities.
- Maintain and continually improve the QEMS.

Originally issued as Environmental Policy on June 8, 1995

Last revised, approved by OCWA's Board of Directors on April 4, 2024

(This policy is annually reviewed)

3.2 Our Board of Directors, Officers and entire staff will act to ensure the implementation of this Policy and will monitor progress of the Quality & Environmental Management System (QEMS).

3.3 OCWA's QEMS Policy is readily communicated and available to all OCWA personnel, through OCWA's Sharepoint Site. The Owner and members of the public can access the policy through OCWA's public website (www.ocwa.com) A hardcopy of the QEMS Policy is posted as specified in the OP-05 Document and Records Control procedure.

3.4 Essential suppliers and service providers are advised of OCWA's QEMS Policy as per the OP-13 Essential Supplies and Services procedure.



Ontario Clean Water Agency

OPERATIONAL PLAN

Wasaga Beach Well Supply System

QEMS Proc.: OP-02
Rev Date: 2024-08-19
Rev No: 2
Pages: 2 of 2

QUALITY & ENVIRONMENTAL MANAGEMENT SYSTEM (QEMS) POLICY

Reviewed by: Process & Compliance Technician | Approved by: Senior Operations Manager

- 3.5 Corporate Compliance coordinates the annual review and approval of the QEMS Policy by the Board of Directors and communicates the approval to all OCWA employees via an electronic communication.
- 3.6 The current version of the policy indicates the date of the last revision and that the policy is annually reviewed. Electronic and hard-copy documents that include the QEMS Policy will only be required to be updated in years when the Policy has been revised. A complete review/revision history of the QEMS Policy (documenting the annual policy review and/or revision approval date) is accessible to all staff on OCWA's Sharepoint site and is available upon request for external stakeholders.

4. Related Documents

- Current QEMS Policy (Posted on OCWA's Sharepoint site and internet)
- QEMS Policy Revision History (Posted on OCWA's Sharepoint site)
- OP-05 Document and Records Control
- OP-13 Essential Supplies and Services

5. Revision History

Date	Revision #	Reason for Revision
2018-05-25	0	Procedure issued – Section 3.4, 3.5 and 3.6 were added to the information originally set out in the main body of OCWA's Operational Plan (last revision 7 dated 2016-06-22). New sections: Purpose, Definitions, Procedure, Related Documents and a separate Revision History. Minor revisions to wording in s. 3.3 to reference location of posted copy of the policy. Added sections on how annual policy review is conducted (s. 3.5 and s. 3.6) and reference to OP-13 ESS (s. 3.4). The full revision history for the QEMS policy is available on OCWA's intranet.
2024-02-05	1	Replaced reference to OCWA's intranet site with OCWA's Sharepoint site.
2024-08-19	2	The first bullet of the QEMS Policy (approved in 2016) was revised to align with OCWA's updated Mission statement. s. 3.3 and 3.6 were modified to add information/clarify how to access the QEMS Policy and the Policy revision history document. Removed water mark.



OPERATIONAL PLAN

Wasaga Beach Well Supply System

QEMS Proc.: OP-03
Rev Date: 2024-02-07
Rev No: 1
Pages: 1 of 2

COMMITMENT AND ENDORSEMENT

Reviewed by: Process & Compliance Technician

Approved by: Senior Operations Manager

1. Purpose

To document the endorsement of the Operational Plan for the Wasaga Beach Well Supply System by OCWA Top Management and the Corporation of the Town of Wasaga Beach (Owner) and to set out when re-endorsement would be required.

2. Definitions

Top Management – a person, persons or a group of people at the highest management level within an Operating Authority that makes decisions respecting the QMS and recommendations to the Owner respecting the Subject System or Subject Systems

3. Procedure

3.1 The Operational Plan is provided to OCWA Top Management and to the Owner for endorsement. The signed written endorsement is presented in Appendix OP-03A. At a minimum, two members of Top Management must endorse the Operational Plan; however, the Operational Plan is made available to all members of Top Management in the specified document control location (refer to OP-05 Document and Records Control). Endorsement by OCWA's Top Management is represented by Senior Operations Manager and the Safety, Process and Compliance Manager or Regional Hub Manager.

3.2 Any major revision of the operational plan will be re-endorsed by OCWA Top Management and the Owner. Major revisions include:

1. A revision to OCWA's QEMS Policy;
2. A change to both representatives of the facility's Top Management and/or both of the Owner's representatives that endorsed the Operational Plan;
3. A modification to the drinking water system processes/components that would require a change to the description in OP-06 Drinking Water System;
4. The addition of a drinking water subsystem owned by the same Owner to this operational plan.

Any other changes would be considered a minor change and would not require the Operational Plan to be re-endorsed.

4. Related Documents

OP-03A Signed Commitment and Endorsement
OP-05 Document and Records Control
OP-06 Drinking Water System



OPERATIONAL PLAN
Wasaga Beach Well Supply System

QEMS Proc.: OP-03
Rev Date: 2024-02-07
Rev No: 1
Pages: 2 of 2

COMMITMENT AND ENDORSEMENT

Reviewed by: Process & Compliance Technician | Approved by: Senior Operations Manager

5. Revision History

Date	Revision #	Reason for Revision
2018-05-25	0	Procedure issued – Information within OP-03 was originally set out in the main body of OCWA’s Operational Plan (last revision 7 dated 2016-06-22). Procedure provides information on who from Top Management endorses the Operational Plan (s. 3.1); when owner re-endorsement is sought and ‘criteria’ as to what is considered a major revision to the Plan (s. 3.2). The Owner and Top Management sign-off section is Appendix OP-03A.
2024-02-07	1	Added in that the Endorsement by OCWA’s Top Management could also (and/or) be represented by the Safety, Process and Compliance Manager.



Ontario Clean Water Agency

OPERATIONAL PLAN

Wasaga Beach Well Supply System

QEMS Doc: OP-03A
Rev Date: 2024-11-18
Rev No: 5
Pages: 1 of 1

SIGNED COMMITMENT AND ENDORSEMENT

This Operational Plan sets out the framework for OCWA' Quality & Environmental Management System (QEMS) that is specific and relevant to your drinking water system(s) and supports the overall goal of OCWA and the Corporation of the Town of Wasaga Beach (Owner) to provide safe, cost-effective drinking water through sustained cooperation. OCWA will be responsible for developing, implementing, maintaining and continually improving its QEMS with respect to the operation and maintenance of the Wasaga Beach Well Supply System and will do so in a manner that ensures compliance with applicable legislative and regulatory requirements.

Through the endorsement of this Operational Plan, the Owner commits to work with OCWA to facilitate this goal.

OCWA Top Management Endorsement



Colin Kasperavicius
Senior Operations Manager, Georgian Bay Hub

2024-11-27
Date

Owner Endorsement



Kevin Lalonde
Director of Public Works

DEC 13/24
Date



Caralynn McRae
Regional Hub Manager, Georgian Highlands Region

2024/12/12
Date



Andrew McNeill
CAO

1/4/2025
Date

The endorsement above is based on the Operational Plan that was current as of the revision date of this document (OP-03A).



OPERATIONAL PLAN

Wasaga Beach Well Supply System

QEMS Proc.: OP-04
Rev Date: 2024-08-29
Rev No: 1
Pages: 1 of 2

QUALITY & ENVIRONMENTAL MANAGEMENT SYSTEM (QEMS) REPRESENTATIVE

Reviewed by: Process & Compliance Technician | Approved by: Senior Operations Manager

1. Purpose

To identify and describe the specific roles and responsibilities of the QEMS Representative(s) for the Wasaga Beach Well Supply System.

2. Definitions

None

3. Procedure

3.1 The role of QEMS Representative for the Wasaga Beach Well Supply System is the Process and Compliance Technician (PCT). The Safety, Process and Compliance Manager (or alternate PCT) will act as an alternate QEMS Representative when required.

3.2 The QEMS Representative is responsible for:

- Administering the QEMS for the Wasaga Beach Well Supply System by ensuring that processes and procedures needed for the facility's QEMS are established and maintained;
- Reporting to Top Management on the facility's QEMS performance and identifying opportunities for improvement;
- Ensuring that current versions of documents related to the QEMS are in use;
- Promoting awareness of the QEMS to all operations personnel; and
- In conjunction with Top Management, ensuring that operations personnel are aware of all applicable legislative and regulatory requirements that pertain to their duties for the operation of the system.

4. Related Documents

None

5. Revision History

Date	Revision #	Reason for Revision
2018-05-25	0	Procedure issued – Information within OP-04 was originally set out in the main body of OCWA's Operational Plan (last revision 7 dated 2016-06-22. New Purpose, Definitions, Procedure, Related Documents and separate Revision History sections. Change to responsibilities: Operations Manager no longer considered QEMS Representative and SPC Manager to act as alternate as required (s. 3.1); added wording to clarify shared responsibilities for Top Management and QEMS Representative to ensure operations personnel are aware of applicable legislative and regulatory requirements (s. 3.2).



Ontario Clean Water Agency

OPERATIONAL PLAN

Wasaga Beach Well Supply System

QEMS Proc.: OP-04
Rev Date: 2014-08-29
Rev No: 1
Pages: 2 of 2

QUALITY & ENVIRONMENTAL MANAGEMENT SYSTEM (QEMS) REPRESENTATIVE

Reviewed by: Process & Compliance Technician | Approved by: Senior Operations Manager

Date	Revision #	Reason for Revision
2024-08-29	1	Removed watermark.



OPERATIONAL PLAN

Wasaga Beach Well Supply System

QEMS Proc.: OP-05
Rev Date: 2024-08-20
Rev No: 9
Pages: 1 of 6

DOCUMENT AND RECORDS CONTROL

Reviewed by: Process & Compliance Technician

Approved by: Senior Operations Manager

1. Purpose

To describe how OCWA's QEMS documents are kept current and how QEMS documents and records are kept legible, readily identifiable, retrievable, stored, protected, retained and disposed of. Applies to QEMS Documents and QEMS records pertaining to the Wasaga Beach Well Supply System, as identified in this procedure.

2. Definitions

Document – includes a sound recording, video tape, film, photograph, chart, graph, map, plan, survey, book of account, and information recorded or stored by means of any device

Record – a document stating results achieved or providing proof of activities performed

QEMS Document – any document required by OCWA's QEMS as identified in this procedure

QEMS Record – any record required by OCWA's QEMS as identified in this procedure

Controlled – managed as per the conditions of this procedure

Retention Period – length of time that a document or record must be kept; starts from the date of issue for QEMS records or from the point of time when a QEMS document is replaced by a new or amended document

3. Procedure

- 3.1 Documents and records required by OCWA's QEMS and their locations are listed in Appendix OP-05A Document and Records Control Locations.
- 3.2 Internally developed QEMS documents and QEMS records (whenever possible) are generated electronically to ensure legibility and are identified through a header/title and revision date. Handwritten records must be legible and permanently rendered in ink or non-erasable marker.
- 3.3 Controls for the Operational Plan include the use of an authorized approval and a header on every page that includes a title, alpha-numeric procedure code, revision date, revision number and page numbers. A revision history is also included at the end of each procedure.

The authorized personnel responsible for the review and approval of this Operational Plan are:

Review: Process & Compliance Technician

Approval: Senior Operations Manager and/or Safety, Process and Compliance Manager



OPERATIONAL PLAN
Wasaga Beach Well Supply System

QEMS Proc.: OP-05
Rev Date: 2024-08-20
Rev No: 9
Pages: 2 of 6

DOCUMENT AND RECORDS CONTROL

Reviewed by: Process & Compliance Technician

Approved by: Senior Operations Manager

The QEMS Representative ensures that updated documents are provided to the above authorized personnel for review or approval prior to issuance.

Authorized personnel authenticate their review/approval of this Operational Plan by using a written signature (scanned or hard copy), using an electronic signature, or via email.

- 3.4 The QEMS Representative is responsible for ensuring that current versions of QEMS documents are being used at all times. Current QEMS documents and records are readily accessible to operations personnel and to internal and external auditors/inspectors at established document control locations. The currency of internal documents is ensured by comparing the date on the document to that of the master hardcopy and/or electronic copy residing in the designated document control location(s) specified in Appendix OP-05A.

Document control locations are established in areas that provide adequate protection to prevent unauthorized use/access, damage, deterioration or loss of QEMS documents and records. Copies of QEMS documents and records located outside of designated control locations are considered uncontrolled.

- 3.5 Access to OCWA's computer network infrastructure is restricted through use of individually-assigned usernames and passwords and local area servers. Network security is maintained by OCWA's Information Technology department through a number of established mechanisms and practices such as daily back-up of files stored on servers, password expiry, limitations on login attempts, multi-factor authentication and policies outlining specific conditions of use.

Access to facility QEMS records contained within internal electronic databases and applications (e.g., Wonderware, OPEX, PDM, WMS) is administered by designated application managers/trustees, requires the permission of Operations Management and is restricted through use of usernames and passwords. Records are protected by means of regular network back-ups of electronic files stored on servers and/or within databases.

SCADA records are maintained as per Appendix OP-05A and are accessible to all staff when required.

- 3.6 Any employee of the drinking water system may request, in writing to the QEMS Representative, a revision be made to improve an existing internal QEMS document or the preparation of a new document. Written requests should indicate the reason for the requested change. The need for new or updated documents may also be identified through the Management Review or system audits.

The QEMS Representative communicates any changes made to QEMS documents to relevant operations personnel and coordinates related training (as required). Changes to corporately controlled QEMS documents are communicated and distributed to facility QEMS Representatives by OCWA's Corporate Compliance Group through e-mails, memos and/or provincial, regional hub/cluster or facility-level training sessions.



OPERATIONAL PLAN
Wasaga Beach Well Supply System

QEMS Proc.: OP-05
Rev Date: 2024-08-20
Rev No: 9
Pages: 3 of 6

DOCUMENT AND RECORDS CONTROL

Reviewed by: Process & Compliance Technician | Approved by: Senior Operations Manager

3.7 When a QEMS document is superseded, the hardcopy and the electronic copy of the document (as applicable) are promptly removed from the applicable designated document control locations specified in OP-05A. The QEMS Representative ensures that the hardcopy and electronic copy are disposed of or retained (as appropriate).

3.8 The authorized method for disposal of hardcopy documents and records after the specified retention requirements have been met is shredding.

The authorized method for disposal of electronic documents and records after the specified retention requirements have been met is deleting.

3.9 QEMS documents and records are retained in accordance with applicable regulations and legal instruments. Relevant regulatory and corporate minimum retention periods are as follows:

Type of Document/Record	Minimum Retention Time	Requirement Reference
Operational Plan (OP-01 to OP-21 and appendices, including Schedule "C" – Subject System Description Form) FEP Long term forecast of major infrastructure maintenance, rehabilitation and renewal activities Sampling plan/schedule/ calendar	10 years	Director's Direction under SDWA
Internal QEMS Audit Results	10 years	OCWA Requirement
External QEMS Audit Results	10 years	OCWA Requirement
Management Review Documentation	10 years	OCWA Requirement
Documents/records required to demonstrate conformance with the DWQMS (specifically documents/records listed in OP-05A)	3 years*if no specified legislative requirement identified in this table or in the facility's legal instruments *	OCWA Requirement
Log Books or other record-keeping mechanisms	5 years	O. Reg. 128/04
Training Records for water operators and water quality analysts	5 years	O. Reg. 128/04
Operational checks, sampling and testing (e.g., chlorine residuals, turbidity, fluoride, sampling records), microbiological sampling and testing and chain of custodies	2 years	O. Reg. 170/03
Schedule 23 & 24 sampling, chain of custodies and test results	6 years LMR 15 years SMR	O. Reg. 170.03



OPERATIONAL PLAN
Wasaga Beach Well Supply System

QEMS Proc.: OP-05
Rev Date: 2024-08-20
Rev No: 9
Pages: 4 of 6

DOCUMENT AND RECORDS CONTROL

Reviewed by: Process & Compliance Technician | Approved by: Senior Operations Manager

Type of Document/Record	Minimum Retention Time	Requirement Reference
THM, HAA, nitrates, nitrites and lead program (including pH and alkalinity) sampling, chain of custodies, and test results, Section 11 Annual Reports and Schedule 22 Summary Reports	6 years	O. Reg. 170/03
Sodium sampling, chain of custody and test results and related corrective action records/reports, 60 month fluoride sampling, chain of custody and test results (if the system doesn't fluoridate), Engineering Reports, GUDI/Non-GUDI Reports	15 years	O. Reg. 170/03
Corrective action records/reports for E. Coli, Total Coliforms and bacterial species	2 years	O. Reg. 170/03
Corrective action records/reports for chemical and radiological parameters under SDWA O. Reg. 169/03, pesticides not listed under O. Reg. 169/03 and health-related parameters in an order or approval	6 years (LMR) 15 years (SMR)	O. Reg. 170/03
Flow Meter Calibration Records, Analyzer Calibration Reports Maintenance Records/Work Orders	2 years	O. Reg. 170/03
Records required by or created in accordance with the Municipal Drinking Water Licence (MDWL) or Drinking Water Works Permit (DWWP). Except records specifically referenced in O. Reg. 170/03 or otherwise specified in the MDWL or DWWP.	5 years	MDWL
Ministry forms referenced in the DWWP, including Form 1, Form 2, Form 3 and Director Notifications (applies to forms that have been completed by OCWA as the authorized by the owner)	10 years	DWWP

3.10 The Operational Plan is reviewed for currency by the QEMS Representative during internal/external audit and Management Review processes. Other QEMS-related documents are reviewed as per the frequencies set out in this Operational Plan or as significant changes (e.g., changes in regulatory requirements, corporate policies or operational processes and/or equipment, etc.) occur. QEMS documents and records are reviewed for evidence of control during each internal system audit as per OP-19 Internal QEMS Audits.



OPERATIONAL PLAN
Wasaga Beach Well Supply System

QEMS Proc.: OP-05
Rev Date: 2024-08-20
Rev No: 9
Pages: 5 of 6

DOCUMENT AND RECORDS CONTROL

Reviewed by: Process & Compliance Technician Approved by: Senior Operations Manager

4. Related Documents

- OP-05A Document and Records Control Locations
- OP-19 Internal QEMS Audits
- OP-20 Management Review Minutes

5. Revision History

Date	Revision #	Reason for Revision
2009-02-04	0	Procedure issued.
2010-08-26	1	CGSB Audit CAR # 550 – Document Control section 5.7.
2011-03-03	2	CGSB Audit CAR # 550 – Revised as per OCWA Corporate Response.
2012-04-26	3	Position Title Change: Operations Manager now Senior Operations Manager.
2014-03-17	4	Revised as per Internal QEMS Audit of March 28, 2013.
2017-01-26	5	Section 5.7 and Table 1 revised as per Internal QEMS Audit of December 20, 2016.
2018-05-25	6	Procedure issued following new template from Corporate Compliance. QP-01 procedure renamed OP-05. Removed Responsibilities and Scope sections. Moved the former Table 1 (Designated location for documents and records required by OCWA's QEMS) to its own appendix (OP-05A). Assigned responsibility for ensuring current versions of QEMS documents are being used to the QEMS Representative (s. 3.4). Clarified that requests for revisions/new QEMS documents are made to the QEMS Representative (s. 3.6). Moved the former Table 2 (Relevant regulatory and corporate minimum retention periods) to be part of s. 3.9 and expanded on the minimum retention times for documents and records required to demonstrate compliance with legislation. Other minor wording changes.
2022-03-31	7	Procedure updated 2022-03-28 following new template from Corporate Compliance. Reason for Revision - Added: clarity to version control requirements to align with the Director's Directions dated May 2021, detail to the approval process for Operational Plan, clarity on how electronic documents are handled and [the process for verifying secure shredding of documents and records]; Updated: the table in section 3.9 (clarified minimum retention time requirements for documents/records required to demonstrate conformance with the DWQMS, added forms required by the MDWL and DWWP, including their minimum retention times and requirement reference)].
2024-02-07	8	Updated section 3.3 to include that Approval can also come from Safety, Process and Compliance Manager in addition to the Senior Operations Manager



OPERATIONAL PLAN
Wasaga Beach Well Supply System

QEMS Proc.: OP-05
Rev Date: 2024-08-20
Rev No: 9
Pages: 6 of 6

DOCUMENT AND RECORDS CONTROL

Reviewed by: Process & Compliance Technician | Approved by: Senior Operations Manager

Date	Revision #	Reason for Revision
2024-08-20	9	Procedure updated as follows: added multi factor authentication to 3.5, section 3.9 table revised to include Schedule 23 & 24 records retention times for Large Municipal Residential (LMR) and Small Municipal Resident (SMR) systems, added chain of custody as record for retention for various sampling requirements, lead program clarified to include pH and alkalinity; added GUDI/Non-GUDI Reports, minor wording and type-o's, removed watermark.



OPERATIONAL PLAN

Wasaga Beach Well Supply System

QEMS Doc: OP-05A
 Rev Date: 2024-08-19
 Rev No: 9
 Pages: 1 of 5

DOCUMENT AND RECORDS CONTROL LOCATIONS

Reviewed by: Process & Compliance Technician Approved by: Senior Operations Manager

Designated locations for documents and records required by OCWA's QEMS

Type of Document/Record	Designated Document Control Location (HC = Hardcopy, E = Electronic)
Internal QEMS Documents	
Operational Plan (OP-01 to OP-21 and appendices, including Schedule "C" – Subject System Description Form)	HC – at Wasaga Beach Public Works Office HC or E – at one other publicly accessible location in the geographical area served by the subject system (at the choosing of the Municipality) E – Hub Server (S:\)
QEMS Policy	E - OCWA's Sharepoint site and public website HC – plaque posted at Wasaga Beach WPCP
Facility Emergency Plans	HC – at Powerline and Jenetta pumphouses E – Hub Server (S:\)
Corporate Emergency Response Plan (CERP)	E - OCWA's Sharepoint site
Standard Operating Procedures (referenced in Operational Plan and QEMS Procedures)	HC – in Facility Emergency Plan located at Powerline and Jenetta pumphouses E – Hub Server (S:\)
Laboratory Manual	HC – at Wasaga Beach WPCP
Essential Supplies & Services List	HC – in Facility Emergency Plan located at Powerline and Jenetta pumphouses E – Hub Server (S:\)
Shift/Vacation Schedule	HC – Annual schedule posted at Wasaga Beach WPCP – updated as requests are approved
On-call Schedule	HC – at Wasaga Beach WPCP E – weekly e-mail notifications
Round Sheet Form	E – Hub Server (S:\)
Sampling Schedule/Plan/Calendar	HC – at Powerline and Jenetta pumphouses E – Hub Server (S:\)
Chain of Custody Forms	E – Hub Server (S:\)
Table of Action Items (Preventive/Corrective Form)	E – Hub Server (S:\)
Contact Time (CT) Charts & Calculations	HC – at Powerline and Jenetta pumphouses E – Hub Server (S:\)
External QEMS Documents	
Maintenance/equipment manuals	HC – at Powerline and Jenetta pumphouses
Engineering System schematics/plans/drawings/diagrams	HC – at Powerline and Jenetta pumphouses E – Hub Server (S:\)
Municipal Drinking Water Licence	HC – in Facility Emergency Plan located at Powerline and Jenetta pumphouses E – Hub Server (S:\)



OPERATIONAL PLAN

Wasaga Beach Well Supply System

QEMS Doc: OP-05A
 Rev Date: 2024-08-19
 Rev No: 9
 Pages: 2 of 5

DOCUMENT AND RECORDS CONTROL LOCATIONS

Reviewed by: Process & Compliance Technician Approved by: Senior Operations Manager

Type of Document/Record	Designated Document Control Location (HC = Hardcopy, E = Electronic)
Drinking Water Works Permit	HC – in Facility Emergency Plan located at Powerline and Jenetta pumphouses E – Hub Server (S:\)
Permit to Take Water	HC – in Facility Emergency Plan located at Powerline and Jenetta pumphouses E – Hub Server (S:\)
Operator certificates	HC – posted at Wasaga Beach WPCP E – Hub Server (S:\)
AWWA Standards	E - \\Torwan\PCT\AWWA Standards
Ontario's Watermain Disinfection Procedure	HC – in Facility Emergency Plan located at Powerline and Jenetta pumphouses E – https://www.ontario.ca
DWQMS Standard	E - https://www.ontario.ca
ANSI/NSF product registration documentation for Chemicals/Materials Used	HC- at Wasaga Beach WPCP E – Hub Server (S:\)
Applicable federal and provincial legislation and municipal by-laws	Provincial Online at www.e-laws.gov.on.ca Federal online at www.laws.justice.gc.ca
Operations Manual Original Equipment Manuals (OEM)	HC – at Powerline and Jenetta pumphouses
Source Water Protection Plan	HC – in Facility Emergency Plan located at Powerline and Jenetta pumphouses E – Hub Server (S:\)
QEMS Records	
Rounds sheets	HC – at Powerline and Jenetta pumphouses & Wasaga Beach WPCP Process data maintained electronically through PDC
Facility Operations Logbook(s)	E- Facility Logbooks maintained electronically through E - eRIS eLOG software https://ocwa.eriscloud.com/ HC – emergency back-up logbooks at the facility pumphouses
Visitor's Logbook	HC – at Powerline and Jenetta pumphouses
Plant Tour Records	HC – at Wasaga Beach WPCP (as applicable)
Operator training records	HC – at Wasaga Beach WPCP E – maintained in OCWA's Training Summary dB
Maintenance records	HC – at Wasaga Beach WPCP E - maintained in WMS (if applicable, list maintenance records not in WMS and location where maintained)
Internal Calibration records	HC – at Wasaga Beach WPCP E - Hub Server (S:\), maintained through WMS
External Calibration records	E – Hub Server (S:\)



OPERATIONAL PLAN

Wasaga Beach Well Supply System

QEMS Doc: OP-05A
 Rev Date: 2024-08-19
 Rev No: 9
 Pages: 3 of 5

DOCUMENT AND RECORDS CONTROL LOCATIONS

Reviewed by: Process & Compliance Technician Approved by: Senior Operations Manager

Type of Document/Record	Designated Document Control Location (HC = Hardcopy, E = Electronic)
Chain of Custodies	E – Hub Server (S:\)
Laboratory analyses	HC – at Wasaga Beach WPCP Electronic reports from Laboratory – Hub Server (S:\) E – maintained through PDM
Additional Sampling records	HC – at Wasaga Beach WPCP E – Hub Server (S:\)
In-house lab results	HC – at Wasaga Beach WPCP E - maintained through PDM
SCADA records (Wonderware, OCWA)	HC – at Powerline pumphouse E - maintained through Wonderware
SCADA Records (Plant SCADA, Client Owned)	E – Hub Server (S:\)
Internal QEMS audit reports	E – Hub Server (S:\)
External audit reports	E – Hub Server (S:\)
Ministry Inspection Reports	E – Hub Server (S:\)
Management Review documentation	E – Hub Server (S:\)
Summary Table of Action Items (Preventive/Corrective records)	E – Hub Server (S:\)
Internal QEMS Communications	E – Hub Server (S:\)
External QEMS Communications (including essential suppliers and service providers)	E – Hub Server (S:\)
Annual Reports	E – Hub Server (S:\)
Summary Reports for Municipalities	E – Hub Server (S:\)
AWQI Reports	E – Hub Server (S:\)
Infrastructure review (capital/maintenance works recommendations)	HC – at Wasaga Beach WPCP E – Hub Server (S:\)
Community complaint records	E – maintained through WMS
Call In/Call Back/Call Out Reports	E – maintained through WMS
Results of emergency test exercises/emergency response debriefs	E – Hub Server (S:\)
Ministry forms referenced in the Drinking Water Works Permit, including Form 1, Form 2, Form 3 and Director Notifications (applies to forms that have been completed by OCWA as the authorized by the owner)	E – Hub Server (S:\)



OPERATIONAL PLAN

Wasaga Beach Well Supply System

QEMS Doc: OP-05A
 Rev Date: 2024-08-19
 Rev No: 9
 Pages: 4 of 5

DOCUMENT AND RECORDS CONTROL LOCATIONS

Reviewed by: Process & Compliance Technician Approved by: Senior Operations Manager

Revision History

Date	Revision #	Reason for Revision
2018-05-25	0	Appendix issued; Table was originally included within the Document and Records Control Procedure (QP-01) (last revision 5 dated 2017-01-26). Added additional types of documents and records that require document control. Changed "Georgian Bay Hub Office" to "Georgian Highlands Region Office." Updated Table to reflect current document control locations.
2018-11-23	1	Added one Operational Plan hard copy location at the Wasaga Beach Public Works Office and a hard copy or electronic version "at other publicly accessible location in the geographical area served by the subject system" (at the choosing of the Municipality). Changed QEMS Reference Manual from hard copy to electronic and OCWA SharePoint Site. Removed specific location for on-call schedule and made general to office. Removed hard copy version for management review documents, annual reports, and summary reports. Added electronic version for AWQI.
2019-03-12	3	Updated to add Overall Responsible Operator Postings as an internal QEMS document: HC and E locations. Removed specific location of the Wasaga Beach WPCP "lab" and used "Georgian Highlands Region Office" instead as per Internal Audit (2018-10-31).
2019-03-25	4	Added "Contact Time (CT) Charts & Calculations" as per Essa Internal Audit (2018-10-30).
2021-06-09	5	Community complaint records now maintained through Work Management System
2022-03-25	6	Updated QEMS Facility Record Logbooks to include new online logbook system. Electronic Facility Logbooks maintained through E - eRIS eLOG software https://ocwa.eriscloud.com/ effective January 1 st , 2022 a backup emergency logbook can also be found at the facility pumphouses.
2022-03-31	7	Added: instructions (specify exact location of documents/records and list maintenance records not in WMS), clarity on which documents are included under the Operational Plan, new documents/records (Watermain Disinfection Procedure, results of emergency test exercises/emergency response debriefs and Ministry forms referenced in the Drinking Water Works Permit) and clarity to external communications and inspection reports; Removed: reference to QEMS Reference Manual and OCWA's Sharepoint Site(replaced with OCWA's Sharepoint site). Added row to header to show who reviewed and approved the document. Removed any references to "Georgian Highlands Region Office" and replaced with Wasaga Beach WPCP location.
2023-01-23	8	Minor edit: Changed wording of 'Chain Custodies' to 'Chain of Custodies' on page 3 as per the recommendation of 2022 Internal Audit. Also removed HC location for Chain of Custodies as they are only kept in electronic form on the Hub Server.



Ontario Clean Water Agency

OPERATIONAL PLAN

Wasaga Beach Well Supply System

QEMS Doc: OP-05A
Rev Date: 2024-08-19
Rev No: 9
Pages: 5 of 5

DOCUMENT AND RECORDS CONTROL LOCATIONS

Reviewed by: Process & Compliance Technician

Approved by: Senior Operations Manager

2024-08-19

9

Procedure updated. Removed reference to "OPEX Database Action Plan Form (Preventive/Corrective)". Appendix updated with MECP revised to Ministry, updated Corporate Emergency Plan (CERP) name, minor wording, removed watermark.

	OPERATIONAL PLAN Wasaga Beach Well Supply System	QEMS Proc.: OP-06 Rev Date: 2024-08-20 Rev No: 6 Pages: 1 of 6
DRINKING WATER SYSTEM		
Reviewed by: Process & Compliance Technicians	Approved by: Senior Operations Manager	

1. Purpose

To document the following for the Wasaga Beach DWS:

- The name of the Owner and Operating Authority; and
- Provide a description of the system, including all applicable water sources, treatment system processes and distribution system components.

2. Definitions

Distribution System - means the part of a drinking water system that is used in the distribution, storage or supply of water and that is not part of a treatment system.

Primary Disinfection - means a process or series of processes intended to remove or inactivate human pathogens such as viruses, bacteria and protozoa in water.

Secondary Disinfection - means a process or series of processes intended to provide and maintain a disinfectant residual in a drinking water system's distribution system, and in plumbing connected to the distribution system, for the purposes of:

- (a) protecting water from microbiological re-contamination;
- (b) reducing bacterial regrowth;
- (c) controlling biofilm formation;
- (d) serving as an indicator of distribution system integrity; and includes the use of disinfectant residuals from primary disinfection to provide and maintain a disinfectant residual in a drinking water system's distribution system for the purposes described in clauses (a) to (d).

Treatment System - means any part of a drinking water system that is used in relation to the treatment of water and includes,

- (a) any thing that conveys or stores water and is part of a treatment process, including any treatment equipment installed in plumbing,
- (b) any thing related to the management of residue from the treatment process or the management of the discharge of a substance into the natural environment from the system, and
- (c) a well or intake that serves as the source or entry point of raw water supply for the system;

3. Procedure

3.1 Drinking Water System Overview

- The Wasaga Beach Well Supply System is owned by the Corporation of the Town of Wasaga Beach. OCWA is the contracted Operating Authority for the Town of Wasaga Beach Well Supply System.
- The Wasaga Beach Drinking Water System is owned and operated by the Corporation of the Town of Wasaga Beach. Details on the distribution system are

	OPERATIONAL PLAN Wasaga Beach Well Supply System	QEMS Proc.: OP-06 Rev Date: 2024-08-20 Rev No: 6 Pages: 2 of 6
DRINKING WATER SYSTEM		
Reviewed by: Process & Compliance Technicians	Approved by: Senior Operations Manager	

included in the Town of Wasaga Beach Public Works “Operational Plan for the Wasaga Beach Distribution System”.

- The Wasaga Beach Well Supply System consists of the following subsystems: the Well Supply System which is represented by two well fields, Treatment System, two (2) Elevated Storage Tanks, One (1) in ground Reservoir and the Sunnidale Booster Station. The Wasaga Beach Well Supply System is part of a Class III Water Distribution and Supply Subsystem.

3.2 Source Water

The Town of Wasaga Beach is located at the southern end of Georgian Bay along the shore of Nottawasaga Bay. The Town obtains potable water solely from groundwater sources located in two well fields, comprising of a total of six (6) wells, referred to as the Powerline Well Pumphouse (Wells 2, 3, and 4) and the Jenetta Well Pumphouse (Wells 1, 2, and 3).

General Characteristics

The raw water source for the treatment plants is ground water wells housed inside each well pumphouses. Bacteriological analysis of the raw water indicates a source of relatively good quality.

Powerline Well Pumphouse

The wells at the Powerline Well Pumphouse are all constructed in a confined artesian aquifer and are not under the influence of surface water. Extensive testing has been done which indicates that the lower water aquifer behaves as a confined artesian aquifer. Tritium age dating indicates the water is approximately 45 years old. Observation well monitoring indicates small seasonal declines in the lower aquifer and no change in the upper aquifer due to water taking from the lower aquifer.

Jenetta Well Pumphouse

The wells at the Jenetta Well Pumphouse are constructed adjacent to Wasaga Beach Provincial Park in a confined artesian aquifer. Pumping tests indicate that the wells did not affect shallow observation wells or wells constructed in the Nottawasaga River bed, nor did surface water effect these wells during recovery from the pumping test. Evidence indicates that these wells are not under the influence of surface water. Tritium age dating indicates the water from these wells is in excess of 50 years old.



OPERATIONAL PLAN

Wasaga Beach Well Supply System

QEMS Proc.: OP-06
Rev Date: 2024-08-20
Rev No: 6
Pages: 3 of 6

DRINKING WATER SYSTEM

Reviewed by: Process & Compliance Technicians | Approved by: Senior Operations Manager

Raw Water Bacteriological Characteristics (based on 2023 data)

Source	Number of Samples	Range of E. Coli Results [orgs/100 mL]	Range of Total Coliform Results [orgs/100 mL]
Powerline Well #2	52	0 - 0	0 - 0
Powerline Well #3	52	0 - 0	0 - 0
Powerline Well #4	43	0 - 0	0 - 0
Jenetta Well #1	43	0 - 0	0 - 0
Jenetta Well #2	52	0 - 0	0 - 0
Jenetta Well #3	52	0 - 0	0 - 0

Raw Water Characteristics for Turbidity (based on 2023 data)

Source	Number of Grab Samples	Range of Turbidity Results (min) - (max) [NTU]
Powerline Well #2	12	0.10 – 0.40
Powerline Well #3	12	0.08 – 0.36
Powerline Well #4	10	0.11 – 0.40
Jenetta Well #1	10	0.07 – 0.59
Jenetta Well #2	12	0.14 – 0.54
Jenetta Well #3	12	0.06 – 0.51

Common Fluctuations

There are no known or observed common fluctuations within the Wasaga Beach Well Supply System.

Threats

The surrounding area is largely rural with wilderness (Wasaga Beach Provincial Park). Land use beyond the provincial park is largely farming; however, significant parts of the surrounding are stream valleys and bog. This area includes the Minesing Swamp and Nottawasaga River Valley. There is a narrow urban area between the wells at the Jenetta Well Pumphouse and the Wasaga Beach Provincial Park. This urban area is predominantly residential with very little industry. The Town of Wasaga Beach is serviced with a municipal sewage treatment system and discharges to the Nottawasaga River. The risk of bacteriological contamination at these wells is low given the aquifers thick confining layer.

The report describes the wells at Wasaga Beach as being constructed in the deepest overburden aquifer of a local multiple aquifer system. According to the report the wells are not under the direct influence of surface water.

In January 2015, the Nottawasaga Valley Source Protection Area Approved Assessment Report was completed with Chapter 17 covering the Town of Wasaga Beach Drinking Water Supply System. This report examined the wellhead protection area and assessed groundwater vulnerability with the intent of identifying any drinking water issues. To quote from this report “No Drinking Water Issues were identified for the Wasaga Beach municipal water supply system.”

	OPERATIONAL PLAN Wasaga Beach Well Supply System	QEMS Proc.: OP-06 Rev Date: 2024-08-20 Rev No: 6 Pages: 4 of 6
DRINKING WATER SYSTEM		
Reviewed by: Process & Compliance Technicians	Approved by: Senior Operations Manager	

The community of Wasaga Beach is serviced by six (6) municipal ground water wells, which lies at depth and appears to be well protected from surficial activities. This assumption is supported by microbiological and turbidity results for the years 2011 to 2015 (period covered by the Nottawasaga Valley Source Protection Area Approved Assessment Report), which indicate good water quality.

Operational Challenges

The main operational challenge is during the summer months when there is a significant increase in water usage by residents. This requires more continuous monitoring of the Storage Tower levels and operational checks of the high lift and well pumps. There is also coordination work required on occasion with the Town of Wasaga Beach Public Works as they are the Owner and Operating Authority for the distribution system.

3.3 Treatment System Description

The Wasaga Beach Well Supply System consists of two (2) water treatment facilities known as Powerline Well Pumphouse and Jenetta Well Pumphouse. The maximum flow rate from each facility is 10,908 L/min.

Powerline Well Pumphouse

Consisting of three (3) wells equipped with vertical turbine pumps; five (5) high lift vertical turbine pumps; one (1) high lift vertical turbine pump (Jockey); one (1) 500 kW diesel generator set for backup power for highlift pumps; one (1) 175 kW diesel generator set for backup power for the well pumps; a sodium silicate feed system for iron sequestering; and a sodium hypochlorite feed system for primary disinfection.

Jenetta Well Pumphouse

Consisting of three (3) wells equipped with vertical turbine pumps; one (1) 400 kW diesel generator set for backup power for the well pumps; a sodium silicate feed system for iron sequestering; a sodium hypochlorite feed system for primary disinfection. A fourth well has been drilled at this site for future development.

Sunnidale Trails Booster Pumping Station

The Sunnidale Trails Booster Pumping Station provides the Sunnidale Trails development area with adequate pressure. The Pumping Station consists of four (4) Horizontal Split Case booster pumps; a re-chlorination system with two (2) metering pumps fed by a chemical tank; and one (1) 300 kW diesel generator set for backup power for the booster pumps and appurtenances.

Monitoring and Recording

Continuous online analyzers monitor turbidity and free chlorine residual. Process data is monitored and recorded on a SCADA system located at the Powerline Well Pumphouse on Veterans Way, at the Wasaga Beach WPCP on Woodland Drive, and the Sunnidale Trails Booster Station. The system is alarmed for a number of parameters including free chlorine residual, turbidity, and system pressure and reservoir level. The alarms are monitored by Huronia Alarms (Midland, Ontario).



OPERATIONAL PLAN
Wasaga Beach Well Supply System

QEMS Proc.: OP-06
Rev Date: 2024-08-20
Rev No: 6
Pages: 5 of 6

DRINKING WATER SYSTEM

Reviewed by: Process & Compliance Technicians | Approved by: Senior Operations Manager

3.4 Treatment System Process Flow Chart

Please refer to OP-06A for the “Site Location Map” and “System Schematic” for the Powerline Well Pumphouse, the Jenetta Well Pumphouse, and the Sunnidale Trails Booster Station.

3.5 Description of the Distribution System Components

Details on the distribution system are included in the Town of Wasaga Beach Public Works “Operational Plan for the Wasaga Beach Distribution System”. OCWA is the operating authority for the distribution water that is stored in the two elevated storage tanks and reservoir. The two elevated storage tanks each have capacities of 2,837.5 cubic meters and 9,550 cubic meters respectively. Additional storage is achieved in the 3,405 cubic meter underground reservoir located at the Powerline Well Pumphouse.

4. Related Documents

Operations & Maintenance Manual
Nottawasaga Valley Source Protection Area Approved Assessment Report
Site Location Map
System Schematic

5. Revision History

Date	Revision #	Reason for Revision
2018-05-25	0	Procedure issued – Information within OP-06 was originally set out in the Main body of OCWA’s Operational Plan (last revision 7 dated 2016-06-22). New Purpose, Definitions, Procedure, Related Documents and separate Revision History sections. Updates based on revisions to DWQMS (e.g. removal of critical upstream or downstream processes, separation of systems that provide primary and/or secondary disinfection and systems that do not, for systems that are connected to another system with different owners, must now include which system is relied upon to ensure the provision of safe drinking water). Moved order of system description to follow the process (e.g., source water first, then treatment, then distribution). Removed “Road” and “Street.” Changed “Powerline Road” to “Powerline Well Pumphouse” and “Jenetta Street” to “Jenetta Well Pumphouse.”
2018-12-12	1	Updated as per Internal Audit Report issued on 2018-12-10: revised raw water characteristics table with 2017 data (latest); included clarification about the “2011 to 2015” data referenced in the Nottawasaga Report; and included a reference to “primary” disinfection for the sodium hypochlorite equipment at both pumphouses.
2019-03-12	2	Updated raw water quality with process data from 2018 as per Internal Audit (2018-10-31).
2021-11-26	3	Sunnidale Trails Booster Station added to Drinking Water System description. 06A updated with new drawings.



OPERATIONAL PLAN
Wasaga Beach Well Supply System

QEMS Proc.: OP-06
Rev Date: 2024-08-20
Rev No: 6
Pages: 6 of 6

DRINKING WATER SYSTEM

Reviewed by: Process & Compliance Technicians | Approved by: Senior Operations Manager

Date	Revision #	Reason for Revision
2022-03-31	4	Removed reference to Powerline Well 1 as Powerline Well 1 has been decommissioned as of June 2021, as such it is no longer a well source for the system.
2023-01-23	5	Full update of this Operational Plan Element- Based on external audit recommendation removing most references to the Wasaga Beach Distribution System as it is both owned and operated by the Town of Wasaga Beach and covered in the "Operational Plan for the Wasaga Beach Distribution System" and focused on the Wasaga Beach Well Supply System. Updated the 2018 data on the Raw Water Characteristics for Turbidity and Bacteria to 2022 data. Remerged the header of "Revision History" to the table and provided greater clarity on the Owner and Operator Roles (3.1) as well as provided an outline of what this element will achieve (3.2) as per 2022 Internal Audit recommendation.
2024-08-20	6	Updated the 2022 data on the Raw Water Characteristics for Turbidity and Bacteria to 2023 data. Updated to the new format. General formatting changes. Removed watermark.



NOTTAWASAGA BAY

WASAGA BEACH
PROVINCIAL PARK

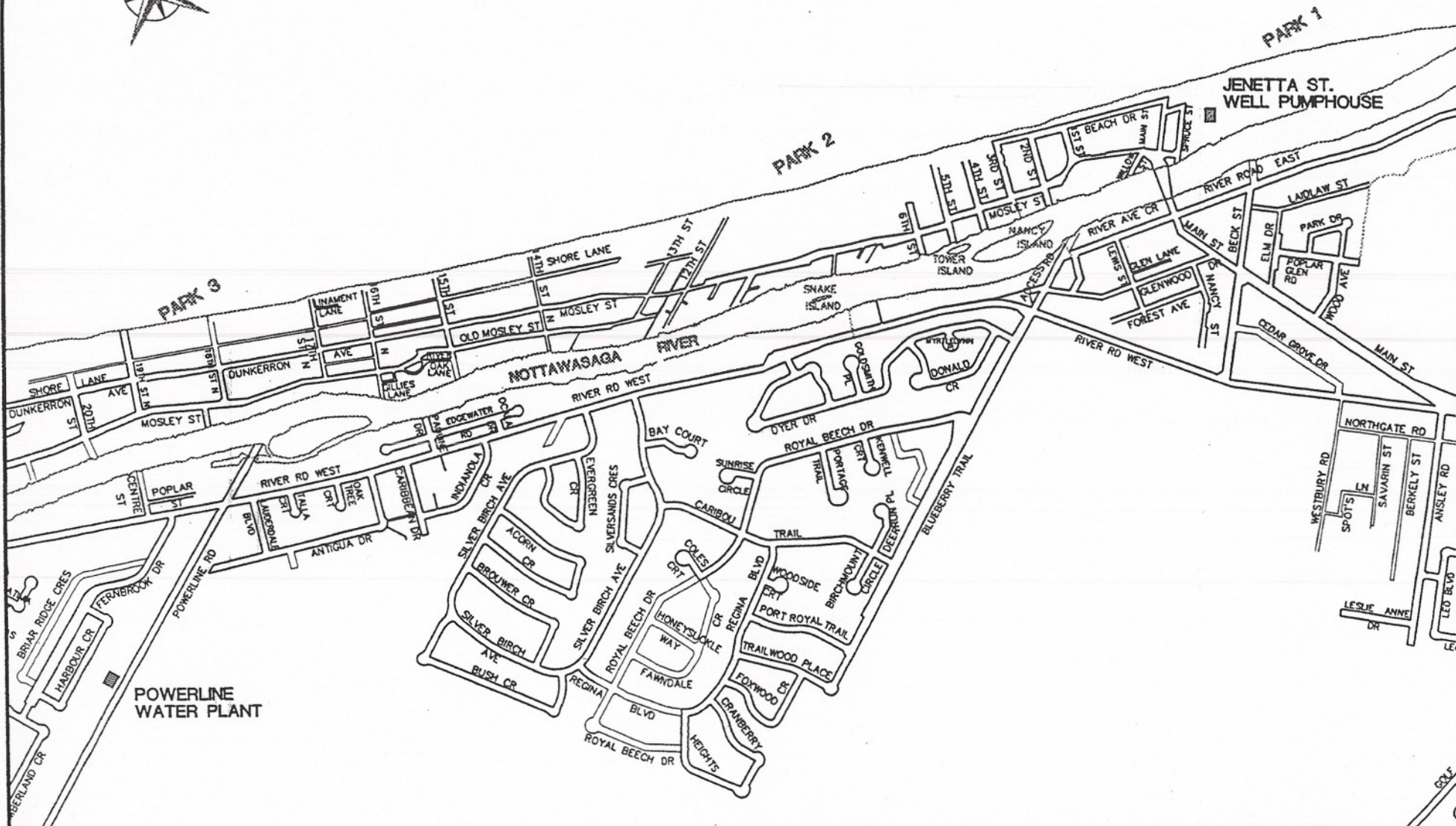

Minley
CONSULTING
ENGINEERS
PLANNERS

TOWN OF WASAGA BEACH
WATER SUPPLY
SITE LOCATION MAP

SCALE: N.T.S.
DATE: MAY 2004
DWG. 103114-FIG 1

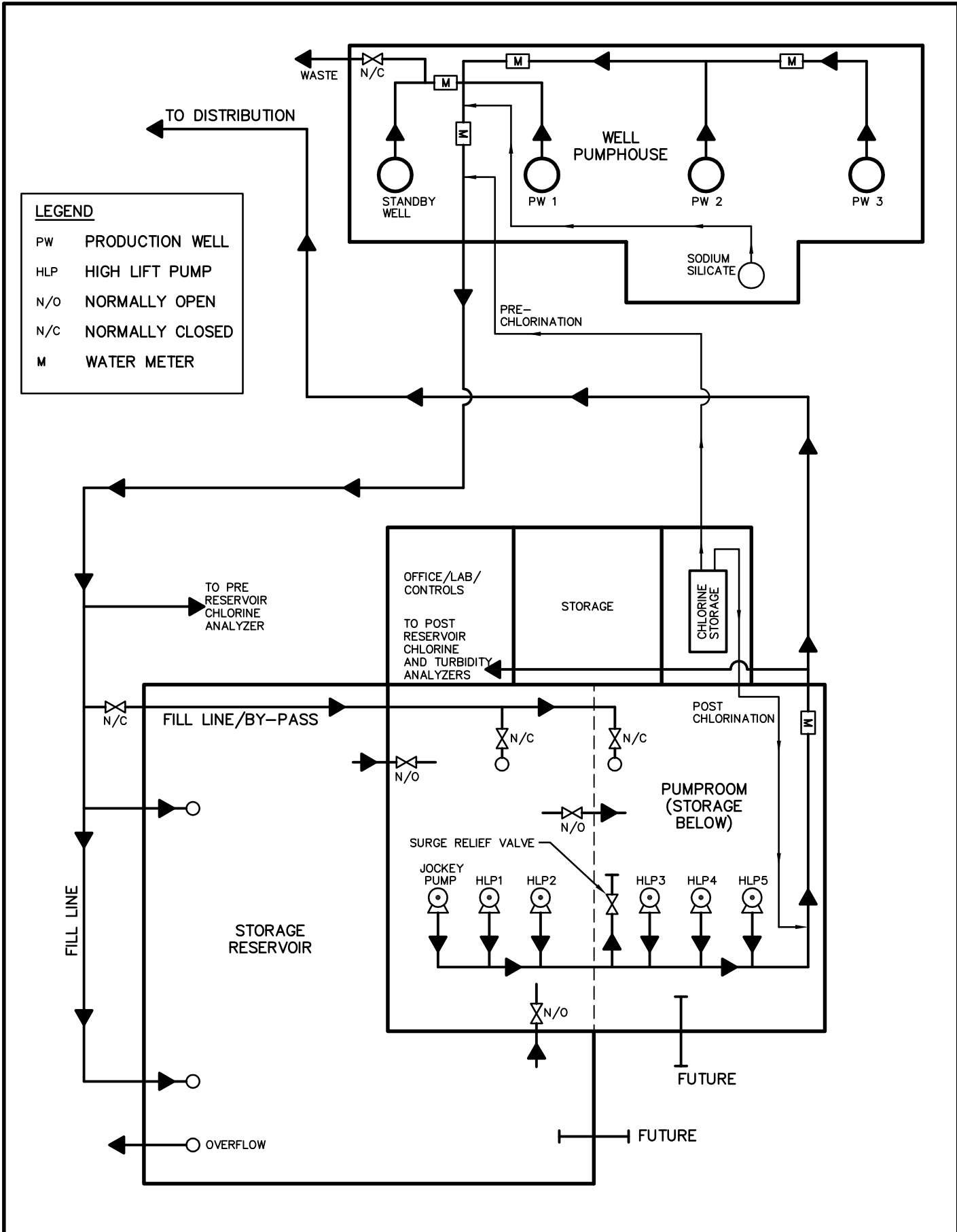

TOWN OF WASAGA BEACH
POWERLINE ROAD WELL PUMPHOUSE & STORAGE RESERVOIR
SYSTEM SCHEMATIC

SCALE: N.T.S.
 DATE: JANUARY 2013
 DWG. 103114-FIG.1

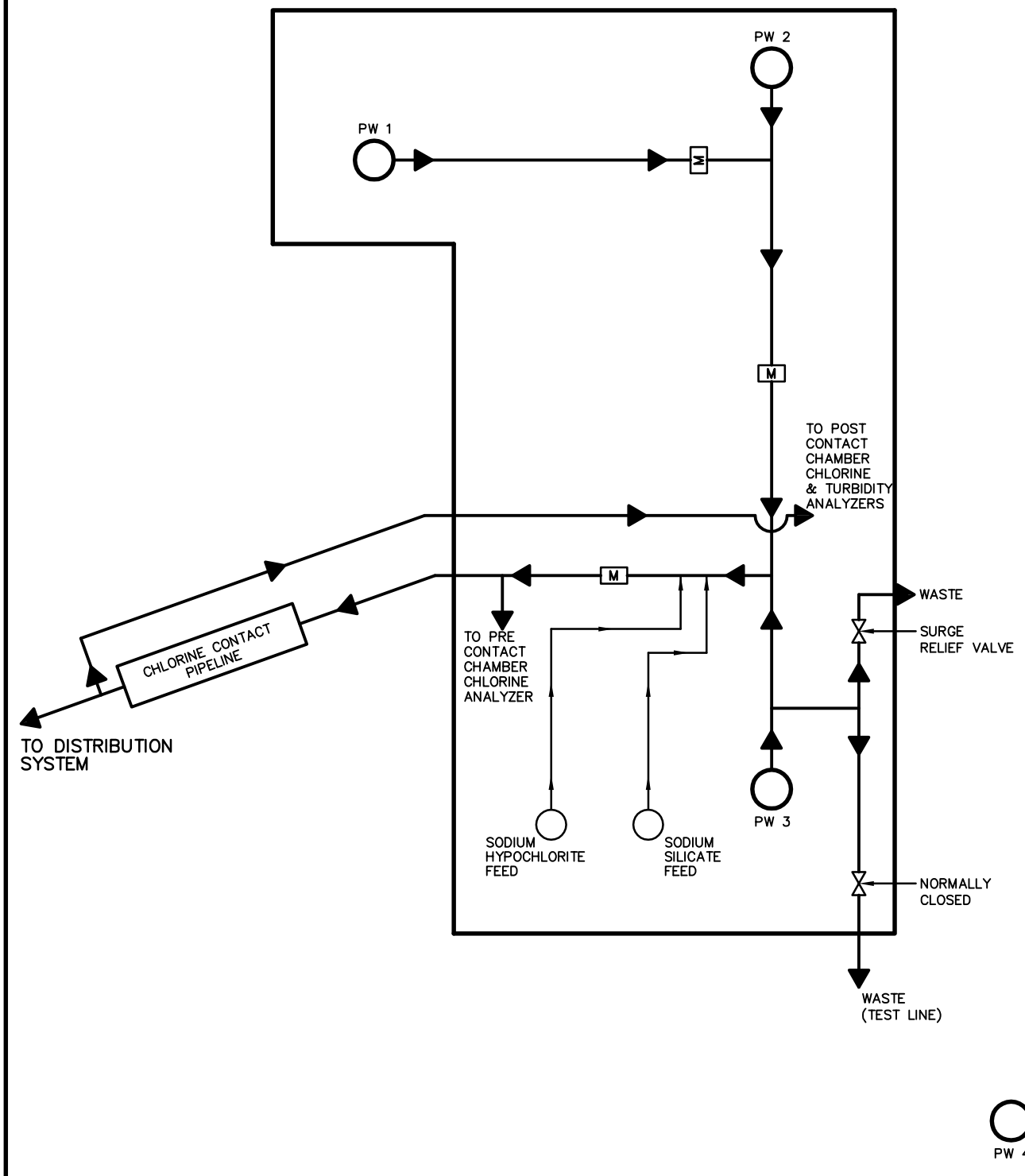

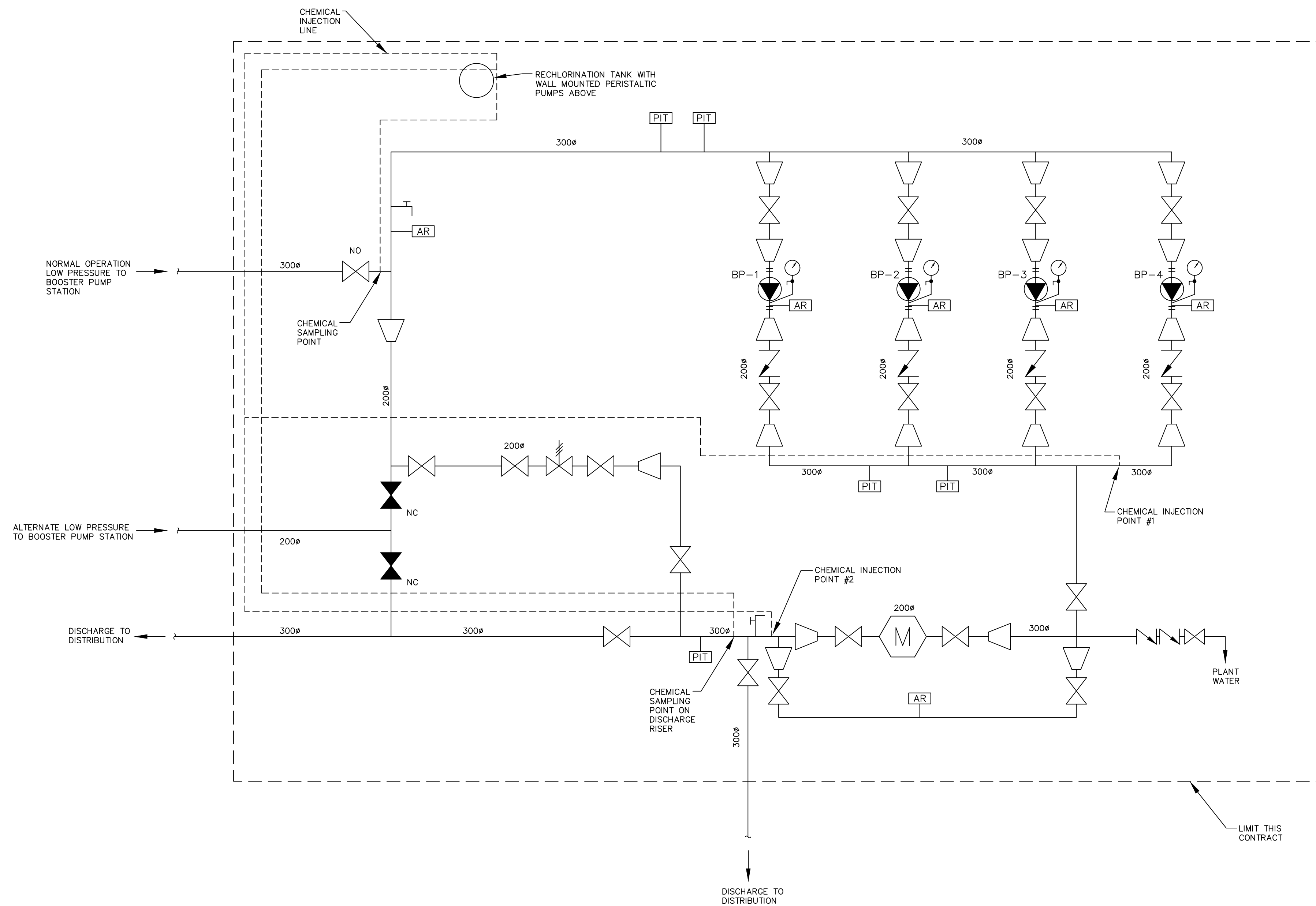

LEGEND

- PROCESS PIPE
- OVERFLOW PIPE
- MAG METER
- PUMP ASSEMBLY
- PLUG VALVE
- MOTORIZED BALL VALVE
- BALL VALVE
- GATE VALVE
- BUTTERFLY VALVE
- CHECK VALVE
- PRESSURE RELIEF VALVE
- PRESSURE GAUGE
- BACK PRESSURE CONTROL VALVE
- REDUCER
- NORMALLY OPEN VALVE
- NORMALLY CLOSED VALVE
- MOTORIZED VALVE
- BACKFLOW PREVENTER VALVE
- SAMPLE POINT
- AIR RELIEF VALVE
- PRESSURE TRANSMITTER



PROJECT
 TOWN OF
 WASAGA BEACH
 SUNNIDALE ROAD
 SEWAGE & WATER
 BOOSTER PUMPING
 STATION

CLIENT
 SUNNIDALE TRAILS
 DEVELOPERS

CONSULTANT
 AECOM Canada Ltd.
 55 Cedar Pointe Drive, Suite 620
 Barrie, Ontario, Canada, L4N 5R7
 705.721.9222 tel 705.734.0764 fax
 www.aecom.com

APPROVALS

REGISTRATION

ISSUE/REVISION

I/R	DATE	DESCRIPTION
7	JAN 2022	AS CONSTRUCTED
6	JULY 2019	ISSUED FOR APPROVAL
5	MAY 2019	ISSUED FOR REVIEW - 3rd SUBM.
4	OCT 2018	ISSUED FOR REVIEW - 2nd SUBM.
3	SEPT 2018	ISSUED FOR TENDER
2	JUNE 2018	ISSUED FOR REVIEW
1	JUNE 2017	ISSUED FOR MOECC APPROVAL

KEY PLAN

PROJECT NUMBER
 60120111

SHEET TITLE
 WATER BOOSTER PUMPING STN.
 PROCESS PLAN
 P & I DIAGRAM - WATER

SHEET NUMBER
 P-1

This drawing has been prepared for the use of AECOM's client and may not be used, reproduced or relied upon by third parties, except as agreed by AECOM and its client, as required by law or for use by governmental reviewing agencies. AECOM accepts no responsibility, and denies any liability whatsoever, to any party that modifies this drawing without AECOM's express written consent. Do not scale this document. All measurements must be obtained from scaled dimensions.



OPERATIONAL PLAN

Wasaga Beach Well Supply System

QEMS Proc.: OP-07
Rev Date: 2024-04-29
Rev No: 2
Pages: 1 of 4

RISK ASSESSMENT

Reviewed by: Process & Compliance Technician | Approved by: Senior Operations Manager

1. Purpose

To document the process for conducting a risk assessment to identify and assess potential hazardous events and associated hazards that could affect drinking water safety.

2. Definitions

Consequence – the potential impact to public health and/or operation of the drinking water system if a hazard/hazardous event is not controlled

Control Measure – includes any processes, physical steps or other practices that have been put in place at a drinking water system to prevent or reduce a hazard before it occurs

Critical Control Point (CCP) – An essential step or point in the subject system at which control can be applied by the Operating Authority to prevent or eliminate a drinking water health hazard or reduce it to an acceptable level

Drinking Water Health Hazard – means, in respect of a drinking water system,

- a) a condition of the system or a condition associated with the system's waters, including any thing found in the waters,
 - i. that adversely affects, or is likely to adversely affect, the health of the users of the system,
 - ii. that deters or hinders, or is likely to deter or hinder, the prevention or suppression of disease, or
 - iii. that endangers or is likely to endanger public health,
- b) a prescribed condition of the drinking water system, or
- c) a prescribed condition associated with the system's waters or the presence of a prescribed thing in the waters

Hazardous Event – an incident or situation that can lead to the presence of a hazard

Hazard – a biological, chemical, physical or radiological agent that has the potential to cause harm

Likelihood – the probability of a hazard or hazardous event occurring

3. Procedure

- 3.1 Operations Management ensures that operations personnel are assigned to conduct a risk assessment at least once every thirty-six months. At a minimum, the Risk Assessment Team must include the QEMS Representative, at least one Operator for the system and at least one member of Operations Management.
- 3.2 The QEMS Representative is responsible for coordinating the risk assessment and ensuring that documents and records related to the risk assessment activities are maintained.



OPERATIONAL PLAN

Wasaga Beach Well Supply System

QEMS Proc.: OP-07
Rev Date: 2024-04-29
Rev No: 2
Pages: 2 of 4

RISK ASSESSMENT

Reviewed by: Process & Compliance Technician | Approved by: Senior Operations Manager

3.3 The Risk Assessment Team performs the risk assessment as follows:

- 3.3.1 OP-07 Risk Assessment and OP-08 Risk Assessment Outcomes are reviewed.
- 3.3.2 For each of the system's activities/process steps, potential hazardous events and associated hazards (possible outcomes) that could impact the system's ability to deliver safe drinking water are identified. At a minimum, potential hazardous events and associated hazard as identified in the most current version of the Ministry document titled "Potential Hazardous Events for Municipal Residential Drinking Water Systems" (as applicable to the system type) must be considered.
- 3.3.3 For each of the hazardous events, control measures currently in place at the system to eliminate the hazard or prevent it from becoming a threat to public health are specified. Control measures may include alarms, monitoring procedures, SOPs/contingency plans, preventive maintenance activities, backup equipment, engineering controls, etc.
- 3.3.4 To ensure that potential drinking water health hazards are addressed and minimum treatment requirements as regulated by SDWA O. Reg. 170/03 and the Ministry's "Procedure for Disinfection of Drinking Water in Ontario" (as amended) are met, OCWA has established mandatory Critical Control Points (CCPs).

As a minimum, the following must be included as CCPs (as applicable):

- Equipment or processes required to achieve primary disinfection (e.g., chemical and/or UV disinfection system, coagulant dosing system, filters, etc.)
 - Equipment or processes necessary for maintaining secondary disinfection in the distribution system
 - Fluoridation system
- 3.3.5 Additional CCPs for the system are determined by evaluating and ranking the hazardous events for the remaining activities/process steps (i.e., those not included as OCWA's minimum CCPs).
 - 3.3.6 Taking into consideration existing control measures (including the reliability and redundancy of equipment), each hazardous event is assigned a value for the likelihood and a value for the consequence of that event occurring based on the following criteria:



OPERATIONAL PLAN
Wasaga Beach Well Supply System

QEMS Proc.: OP-07
Rev Date: 2024-04-29
Rev No: 2
Pages: 3 of 4

RISK ASSESSMENT

Reviewed by: Process & Compliance Technician Approved by: Senior Operations Manager

Value	Likelihood of Hazardous Event Occurring
1	Rare – Estimated to occur every 50 years or more (usually no documented occurrence at site)
2	Unlikely – Estimated to occur in the range of 10 – 49 years
3	Possible – Estimated to occur in the range of 1 – 9 years
4	Likely – Occurs monthly to annually
5	Certain – Occurs monthly or more frequently

Value	Consequence of Hazardous Event Occurring
1	Insignificant – Little or no disruption to normal operations, no impact on public health
2	Minor – Significant modification to normal operations but manageable, no impact on public health
3	Moderate – Potentially reportable, corrective action required, potential public health impact, disruption to operations is manageable
4	Major – Reportable, system significantly compromised and abnormal operations if at all, high level of monitoring and corrective action required, threat to public health
5	Catastrophic – Complete failure of system, water unsuitable for consumption

The likelihood and consequence values are multiplied to determine the risk value (ranking) of each hazardous event. Hazardous events with a ranking of 12 or greater are considered high risk.

- 3.3.7 Hazardous events and rankings are reviewed and any activity/process step is identified as an additional CCP if all of the following criteria are met:
- ✓ The associated hazardous event has a ranking of 12 or greater;
 - ✓ The associated hazardous event can be controlled through control measure(s);
 - ✓ Operation of the control measures can be monitored and corrective actions can be applied in a timely fashion;
 - ✓ Specific control limits can be established for the control measure(s); and
 - ✓ Failure of the control measures would lead to immediate notification of Medical Officer of Health (MOH) or Ministry or both.

- 3.4 The outcomes of the risk assessment are documented as per OP-08 Risk Assessment Outcomes.



OPERATIONAL PLAN
Wasaga Beach Well Supply System

QEMS Proc.: OP-07
Rev Date: 2024-04-29
Rev No: 2
Pages: 4 of 4

RISK ASSESSMENT

Reviewed by: Process & Compliance Technician | Approved by: Senior Operations Manager

3.5 At least once every calendar year, the QEMS Representative facilitates the verification of the currency of the information and the validity of the assumptions used in the risk assessment in preparation for the Management Review (OP-20). When performing this review, the following may be considered:

- Process/equipment changes
- Reliability and redundancy of equipment
- Emergency situations/service interruptions
- CCP deviations
- Audit/inspection results
- Changes to the Ministry document “Potential Hazardous Events for Municipal Residential Drinking Water Systems” (as amended)

4. Related Documents

OP-08 Risk Assessment Outcomes
OP-20 Management Review
Ministry’s “Potential Hazardous Events for Municipal Residential Drinking Water Systems” (as amended)
Ministry’s “Procedure for Disinfection of Drinking Water in Ontario” (as amended)

5. Revision History

Date	Revision #	Reason for Revision
2018-05-25	0	Procedure issued – Information within OP-07 was originally set out in the QEMS Procedure QP-02 Risk Assessment and Risk Assessment Outcomes (last revision 3 dated 2014-10-11). Revised Purpose to reflect element 7 requirements only. Included minimum requirements for the Risk Assessment Team (QEMS Representative, at least one operator for the system and at least one member of Operation Management). Clarified role of QEMS Representative in coordinating the risk assessment and maintaining documents and records. Re-worded procedure for performing the risk assessment (process itself remains essentially unchanged). Included reference to MOECC’s “Potential Hazardous Events for Municipal Residential Drinking Water Systems”. Removed requirements for documenting the outcomes of the risk assessment (now covered in OP-08). Changed annual review to at least once every calendar year and included potential considerations when performing the review.
2020-01-02	1	Any reference to the MOECC was updated to MECP, as identified in the 2019 Internal Audit process.
2024-04-29	2	Procedure updated to point to the most current version of the document and added the Ministry document “Potential Hazardous Events for Municipal Residential Drinking Water Systems” (as amended) to the list of items that may be considered when performing the annual verification of the currency of the information in the risk assessment.

	OPERATIONAL PLAN Wasaga Beach Well Supply System	QEMS Proc.: OP-08 Rev Date: 2024-08-20 Rev No: 3 Pages: 1 of 2
RISK ASSESSMENT OUTCOMES		
Reviewed by: Process & Compliance Technician	Approved by: Senior Operations Manager	

1. Purpose

To document the outcomes of the risk assessment conducted as per OP-07 Risk Assessment.

2. Definitions

Critical Control Point (CCP) – An essential step or point in the subject system at which control can be applied by the Operating Authority to prevent or eliminate a drinking water health hazard or reduce it to an acceptable level

Critical Control Limit (CCL) – The point at which a Critical Control Point response procedure is initiated

3. Procedure

3.1 The QEMS Representative is responsible for updating the information in OP-08A Summary of Risk Assessment Outcomes as required.

3.2 The results of the risk assessment conducted as per OP-07 are documented in Table 1 of OP-08A. This includes:

- Identified potential hazardous events and associated hazards (possible outcomes) for each of the system’s activities/process steps;
 Note: Hazards listed in the Ministry’s “Potential Hazardous Events for Municipal Residential Drinking Water Systems” (as amended) are indicated in the appropriate column using the reference numbers in Table 4 of OP-08A.
- Identified control measures to address the potential hazards and hazardous events; and
- Assigned rankings for the hazardous events (likelihood x consequence = risk value) and whether the hazardous event is a Critical Control Point (CCP) (mandatory or additional).
 Note: If the hazardous event is ranked as 12 or higher and it is not being identified as a CCP, provide rationale as to why it does not meet the criteria set out in section 3.3.7 of OP-07).

3.3 Operations Management is responsible for ensuring that for each CCP:

- Critical Control Limits (CCLs) are set;
- Procedures and processes to monitor the CCLs are established; and
- Procedures to respond to, report and record deviations from the CCLs are implemented.

The identified CCPs, their respective CCLs and associated procedures are documented in Table 2 of OP-08A.



OPERATIONAL PLAN
Wasaga Beach Well Supply System

QEMS Proc.: OP-08
Rev Date: 2024-08-20
Rev No: 3
Pages: 2 of 2

RISK ASSESSMENT OUTCOMES

Reviewed by: Process & Compliance Technician | Approved by: Senior Operations Manager

- 3.4 A summary of the results of the annual review/36-month risk assessment is recorded in Table 3 of OP-08A.
- 3.5 Operations Management considers the risk assessment outcomes during the review of the adequacy of the infrastructure (Refer to OP-14 Review and Provision of Infrastructure).

4. Related Documents

- OP-07 Risk Assessment
- OP-08A Summary of Risk Assessment Outcomes
- OP-14 Review and Provision of Infrastructure
- Ministry’s “Potential Hazardous Events for Municipal Residential Drinking Water Systems” (as amended)

5. Revision History

Date	Revision #	Reason for Revision
2018-06-21	0	Procedure issued – Information within OP-08 was originally set out in the Main body of OCWA’s Operational Plan (last revision 7 dated 2016-06-22). Clarified role of QEMS Representative in updating the information in OP-08A Summary of Risk Assessment Outcomes. Included requirements for how to document the risk assessment outcomes using the tables in OP-08A. Clarified responsibility of Operations Management to ensure Critical Control Limits are set and related procedures are developed. Included reference to OP-14 Review and Provision of Infrastructure to emphasize the need for Operations Management to review
2020-01-02	1	Any reference to the MOECC was updated to MECP, as identified in the 2019 Internal Audit process.
2024-02-05	2	Procedure updated Added “(as amended)” directly following references to the Ministry’s “Potential Hazardous Events for Municipal Residential Drinking Water Systems” to point to the most current version of the document.
2024-08-20	3	Removed water mark



OPERATIONAL PLAN
Wasaga Beach Well Supply System

QEMS Doc.: OP-08A
Rev Date: 2024-10-03
Rev No: 12
Pages: 1 of 20

SUMMARY OF RISK ASSESSMENT OUTCOMES

Reviewed by: Process & Compliance Technician

Approved by: Senior Operations Manager

Table 1: Risk Assessment Table

Note: Processes referred to in section 3.3.4 of OP-07 Risk Assessment must be identified as mandatory Critical Control Points (CCPs) as applicable. Mandatory CCPs are not required to be ranked.

Activity / Process Step	Ministry's Potential Hazardous Event/Hazard Reference # (see Table 4)	Description of Hazardous Event	Possible Outcome (Hazards)	Existing Control Measures	Likelihood	Consequence	Risk Value	CCP?
Raw Water / Wells	2	Well casing collapse	Loss of raw water	Back-up wells, Back-up pumps, Plant checks by Operator, Well rotation, Well inspections, well and pumping performance tests, Alarms, Call-outs, wells located inside facilities. Turbidity monitored.	1	4	4	<input checked="" type="checkbox"/> No
	2	Well pump failure	Loss of raw water	Back-up wells, Back-up pumps, Preventive Maintenance, Plant checks by Operator, Vendor records (essential suppliers & priority customer), Using only a percentage of capacity outlined in current Municipal Drinking Water License and Permit to Take Water, Trained personnel. Spare parts available.	3	2	6	<input checked="" type="checkbox"/> No
	2, 5	Chemical Spill	Contamination of aquifer	Sampling and Monitoring, Well Head Protection Plan, Spill kits, Spill containment, Plant checks, Standard Operating Procedures, Spill reporting, Back-up chemical totes for temporary storage, Alarms, Call-outs, Lock-outs, upgrades to chemical system, using chemically compatible materials (Viton, Teflon, etc.). Upgraded TSSA system.	2	4	8	<input checked="" type="checkbox"/> No



OPERATIONAL PLAN

Wasaga Beach Well Supply System

QEMS Doc.: OP-08A
 Rev Date: 2024-10-03
 Rev No: 12
 Pages: 2 of 20

SUMMARY OF RISK ASSESSMENT OUTCOMES

Reviewed by: Process & Compliance Technician

Approved by: Senior Operations Manager

Activity / Process Step	Ministry's Potential Hazardous Event/Hazard Reference # (see Table 4)	Description of Hazardous Event	Possible Outcome (Hazards)	Existing Control Measures	Likelihood	Consequence	Risk Value	CCP?
	9	Sudden changes to raw water characteristics	Reduced water supply, low chlorine residual, difficulty maintaining secondary disinfection, achieving CT, customer complaints, additional upgrades to existing system required, more chemical usage	Continuous monitoring, Alarms, Call-out, OCWA Process Optimization Team, Jar testing, Increase chemical dosage as required, Sampling and monitoring, Contingency Plan, Trained personnel, weekly raw water bacteriological sampling and turbidity, Source Water Protection Zoning, monitoring the level of production and monitoring wells. Responding to community complaints and inquiries as they arise- recording complaints in the WMS.	2	3	6	<input checked="" type="checkbox"/> No
Primary Disinfection	2, 10	Chemical feed pump failure	Loss of disinfection	Back-up feed system, Spare pumps, Spare parts, Continuous monitoring, Alarms, Call-out, "Pre-Chlorination" analyzer, Plant checks by Operator, Trained personnel, Standard Operating Procedures, Improved piping material selection (Viton, Teflon, etc.) for longevity, alternating pump operation, Preventive Maintenance, pumps added to long-term budget to upgrade and proactively replace, and well lock-out system				<input checked="" type="checkbox"/> Yes – Mandatory CCP
	2, 10	Chlorine analyzer failure	Unknown residual levels, unable to meet CT requirements	Alarms, Call-out, Preventive Maintenance – calibrations, cleaning analyzer body, etc., Hand-held readings, Plant checks by Operator,				<input checked="" type="checkbox"/> Yes – Mandatory CCP



OPERATIONAL PLAN

Wasaga Beach Well Supply System

QEMS Doc.: OP-08A
 Rev Date: 2024-10-03
 Rev No: 12
 Pages: 3 of 20

SUMMARY OF RISK ASSESSMENT OUTCOMES

Reviewed by: Process & Compliance Technician

Approved by: Senior Operations Manager

Activity / Process Step	Ministry's Potential Hazardous Event/Hazard Reference # (see Table 4)	Description of Hazardous Event	Possible Outcome (Hazards)	Existing Control Measures	Likelihood	Consequence	Risk Value	CCP?
				Spare parts, Trained personnel, feed pump for pre-chlorine analyzer, SOP, "common" or standardized spares for systems/units. Spare chlorine analyzer at Powerline pumphouse for emergencies				
Distribution / Secondary Disinfection	2, 10	Loss of chlorine residual	Contamination of distributed water	Sampling and monitoring, Coordination with Town and their distribution crew for inspection, flushing, etc., Continuous monitoring, Alarms, Call-out, Preventive Maintenance, SCADA review, Plant Check, auto-flushing stations within the distribution system.				<input checked="" type="checkbox"/> Yes – Mandatory CCP
	2, 7	Chlorine analyzer failure	Unknown residual levels, unable to meet secondary disinfection 0.05 mg/L residual regulatory requirement	Continuous monitoring, Alarms, Call-out, Manual grab samples in distribution (4 & 3 as per O. Reg 170/03), Standard Operating Procedures, Reporting, Plant checks by Operator, Spare parts, Trained personnel, Preventive Maintenance – calibrations, cleaning analyzer body, etc., <i>plans to add a new analyzer within distribution system as new developments are finalized. Second distribution analyzer at Sunnidale booster station.</i>				<input checked="" type="checkbox"/> Yes – Mandatory CCP
	8	Backflow	Contamination of treated water (public health)	Backflow preventers, Calibration of backflow preventers, Town By-laws (related to plumbing code), Procedures for maintaining system distribution	2	3	6	<input checked="" type="checkbox"/> No



OPERATIONAL PLAN

Wasaga Beach Well Supply System

QEMS Doc.: OP-08A
 Rev Date: 2024-10-03
 Rev No: 12
 Pages: 4 of 20

SUMMARY OF RISK ASSESSMENT OUTCOMES

Reviewed by: Process & Compliance Technician

Approved by: Senior Operations Manager

Activity / Process Step	Ministry's Potential Hazardous Event/Hazard Reference # (see Table 4)	Description of Hazardous Event	Possible Outcome (Hazards)	Existing Control Measures	Likelihood	Consequence	Risk Value	CCP?
				pressures, AWWA standards, and watermain break SOP and public works crew, disinfection of watermain SOP, Town bulk filling station.				
Towers	2	Tower Low Level	Low treated water supply	Tower #1: alarm at low level (adjustable) and dialer, Tower #2: alarm at low level (adjustable), Town Ordered Water Restrictions, Back-up Tower, Multiple high lift pumps with lock-outs, Use of reservoir only, Preventive Maintenance, Continuous monitoring, Call-out, Plant checks by Operators, Standard Operating Procedures	3	3	9	<input checked="" type="checkbox"/> No
	5	Tower High Level	Overflow of Tower	Tower #1: alarm at high level (adjustable) and dialer, Tower #2: alarm at high level (adjustable), Overflows on both towers, Plant checks by Operators, Continuous monitoring, Call-out, Standard Operating Procedures, Dechlorination materials, Reporting, limit switch fail alarm.	3	3	9	<input checked="" type="checkbox"/> No
Reservoir-Powerline	2	Reservoir Low Level	Low treated water supply, impact to CT	Alarm at low level, Call-out, Continuous monitoring, Tower volume(s) available for backup, Standard Operating Procedures, Adjust chlorine injection to maintain CT, Manual monitoring of high lift pumps, well pumps, and reservoir level, spare parts/heads, back-up	3	2	6	<input checked="" type="checkbox"/> No



OPERATIONAL PLAN

Wasaga Beach Well Supply System

QEMS Doc.: OP-08A
 Rev Date: 2024-10-03
 Rev No: 12
 Pages: 5 of 20

SUMMARY OF RISK ASSESSMENT OUTCOMES

Reviewed by: Process & Compliance Technician

Approved by: Senior Operations Manager

Activity / Process Step	Ministry's Potential Hazardous Event/Hazard Reference # (see Table 4)	Description of Hazardous Event	Possible Outcome (Hazards)	Existing Control Measures	Likelihood	Consequence	Risk Value	CCP?
				pumphouse, Town ordered water restrictions/ban				
	5	Reservoir High Level	Overflow	Alarm at high level, Overflow, Dechlorination materials, Reporting, high level lock-out of well pumps, plant checks, SCADA review	3	1	3	<input checked="" type="checkbox"/> No
Distribution System	2, 7	Low Pressure	Distribution pressure low	Alarm at low pressure, Call-out, High lift pumps operate on the tower levels, Plant checks by Operators, Coordination with Town and distribution crew – flushing, local pressure gauges, watermains, hydrants, etc., Communication with Fire Department, Can provide assistance to Town with watermain breaks, Community complaints/feedback policy, AWWA Standards, Boiled Water Advisories, Manual distribution chlorine residuals, Reporting AWQI's, etc., Standard Operating Procedures	3	3	9	<input checked="" type="checkbox"/> No
	2, 7	Sustained Pressure Loss (in the distribution system)	Loss of pressure and water supply, contamination of distribution water	Alarms, Call-out, Trained personnel able to repair leaks and watermain breaks, AWWA standards and training, Coordination with Town and distribution crew – locates, flushing, isolation of watermains, etc., Contractors available to make repairs if required, Boiled water advisories, Alternate water sources (e.g. tanker), Back-up Pumphouse,	1	5	5	<input checked="" type="checkbox"/> No



OPERATIONAL PLAN
Wasaga Beach Well Supply System

QEMS Doc.: OP-08A
Rev Date: 2024-10-03
Rev No: 12
Pages: 6 of 20

SUMMARY OF RISK ASSESSMENT OUTCOMES

Reviewed by: Process & Compliance Technician

Approved by: Senior Operations Manager

Activity / Process Step	Ministry's Potential Hazardous Event/Hazard Reference # (see Table 4)	Description of Hazardous Event	Possible Outcome (Hazards)	Existing Control Measures	Likelihood	Consequence	Risk Value	CCP?
				Back-up Tower, Community complaints /feedback, Manually operating pumps, Contingency Plan, Trained personnel, Central location for access to water within Town (i.e. Recreation Centre), distribution valving for locally maintaining and/or controlling pressure. Multiple sources of water available.				
Control System	2	Power failure	Loss of SCADA, loss of treated water supply, loss of system pressure	UPS, Back-up batteries, Diesel Generators, Digital Chart Recorders, Continuous monitoring, Alarms, Call-outs, Manual operation of pumphouse, Back-up pumphouse, Capital upgrades (SCADA), Portable generator, Essential suppliers list & priority customer, Wasaga Beach Public Works Distribution Hydro Crew contacts	4	1	4	<input checked="" type="checkbox"/> No
	2	Loss of Communication with Huronia Alarms	Loss of Signal Alarm	Portable Dialer, Staff manned as per MOH and Ministry Direction, Alarms, Call-outs, Capital upgrades, dialer at Tower #1, 2 new cell towers to increase communications reliability. Cell phone dialers. System upgrades/alarming improvements planned with future upgrades.	4	1	4	<input checked="" type="checkbox"/> No
	2	Loss of Communication between Powerline	Loss of automatic controls at Jenetta Pumphouse	Jenetta and Powerline Pumphouses can be operated manually and independently from one another, Alarms, Call-outs, Capital upgrades	3	2	6	<input checked="" type="checkbox"/> No



OPERATIONAL PLAN

Wasaga Beach Well Supply System

QEMS Doc.: OP-08A
 Rev Date: 2024-10-03
 Rev No: 12
 Pages: 7 of 20

SUMMARY OF RISK ASSESSMENT OUTCOMES

Reviewed by: Process & Compliance Technician

Approved by: Senior Operations Manager

Activity / Process Step	Ministry's Potential Hazardous Event/Hazard Reference # (see Table 4)	Description of Hazardous Event	Possible Outcome (Hazards)	Existing Control Measures	Likelihood	Consequence	Risk Value	CCP?
		and Jenetta Pumphouses		(SCADA to operate independently and provide redundancy), redundancy with SCADA control from Wasaga Beach WPCP to Pumphouses.				
Partial System	2	Generator failure	Loss of diesel back-up power, loss of treated water supply, loss of system pressure	Back-up Pumphouse, Portable Generator rental, Alarms, Volume of towers, Volume of reservoir, Plant checks by Operators, Preventive Maintenance, Monthly diesel generator run and checklist, Essential suppliers list & priority customer, Standard Operating Procedures, Contingency Plan, Vendor of Records for generator repairs and Rental access.	3	3	9	<input checked="" type="checkbox"/> No
Entire System	2, 7	No Diesel Fuel Supply	Loss of diesel back-up power	Plant checks by Operators, Alarms, Call-out, Essential suppliers list & priority customer, Preventive Maintenance, Reduce duration and/or frequency of monthly diesel generator runs, Local gas stations, fuel cards, local contractors. Town storages of diesel available. TSSA Upgrades.	2	4	8	<input checked="" type="checkbox"/> No
Facility Security	6	Vandalism	Damage to equipment, inability to produce water	Locks, Local building alarms, Drinking water system alarms, Daily checks excluding weekends, Call-out, Signage, Contingency Plan, Bird/insect screens, Reservoir hatches with locks, frequent perimeter checks, building locked and	3	3	9	<input checked="" type="checkbox"/> No
	6	Introduction of contaminant	Potential contamination					



OPERATIONAL PLAN

Wasaga Beach Well Supply System

QEMS Doc.: OP-08A
 Rev Date: 2024-10-03
 Rev No: 12
 Pages: 8 of 20

SUMMARY OF RISK ASSESSMENT OUTCOMES

Reviewed by: Process & Compliance Technician

Approved by: Senior Operations Manager

Activity / Process Step	Ministry's Potential Hazardous Event/Hazard Reference # (see Table 4)	Description of Hazardous Event	Possible Outcome (Hazards)	Existing Control Measures	Likelihood	Consequence	Risk Value	CCP?
				alarmed, reservoir inspection by contractor every five (5) years.				
	6,13	Terrorism	Cyber terrorism	Password protection, Changing passwords, Individual login, Anti-virus programs, Folder permissions, Administrator rights restricted to IT, Data back-up, Back-up monitoring system, IT training staff on internet threats. Increased security through OCWA MFA (multi-factor authentication) logins.	3	3	9	<input checked="" type="checkbox"/> No
			Chemical / bacteriological contamination	Restricted access, Security alarms, Drinking Water System alarms, Monitoring & facility checks, Sampling, Community complaints / feedback, Town by-laws, Police enforcement and patrol, wells inside locked and alarmed buildings.	1	5	5	<input checked="" type="checkbox"/> No
			Confrontation	Restricted access, Pumphouse locks, Security alarms, Contact police, Cellphones, Security Breach Contingency Plan, Trained personnel, Lone worker protocol, Ability to lock one's self inside facility and/or vehicles.	2	4	8	<input checked="" type="checkbox"/> No
All	1	Long term impacts of climate change	Increase/ decrease in water levels in lakes and aquifers (flooding, drought etc.), flooding of pumphouses	<u>Drought</u> : Water conservation, Water use restrictions, Implementation of water meters, Monitoring well level monitoring, Production well level monitoring	3	3	9	<input checked="" type="checkbox"/> No



OPERATIONAL PLAN

Wasaga Beach Well Supply System

QEMS Doc.: OP-08A
 Rev Date: 2024-10-03
 Rev No: 12
 Pages: 9 of 20

SUMMARY OF RISK ASSESSMENT OUTCOMES

Reviewed by: Process & Compliance Technician

Approved by: Senior Operations Manager

Activity / Process Step	Ministry's Potential Hazardous Event/Hazard Reference # (see Table 4)	Description of Hazardous Event	Possible Outcome (Hazards)	Existing Control Measures	Likelihood	Consequence	Risk Value	CCP?
				<u>Flooding</u> : Storm water management ponds, Two Pumphouses (i.e. back-up), Two Towers (i.e. back-up), Alternate water source/supply. Hydrogeological studies conducted on a 5 year assessment for PTTW renewals				
			High winds, tornadoes	Back-up Pumphouses, Back-up Tower, Ability to isolate Pumphouses for safety reasons, Concrete and brick building materials, Manually operate pumphouses, Alarms (e.g. loss of communication from radio signals), police issued road closures.	3	3	9	<input checked="" type="checkbox"/> No
			Source water quality impacted by extreme weather events (e.g. overflows / bypasses at wastewater facilities, leaching from landfills and residential septic tanks, etc.)	Additional raw water sampling/monitoring during overflow / bypass events, Overflow / bypass procedures, Monitoring well sampling and testing, Source water protection designation and signage, Conservation authority monitoring and enforcement, Town by-laws	1	4	4	<input checked="" type="checkbox"/> No
			2	Water Supply Shortfall	Increase in water demand due to increase in population	Water conservation, Water use restrictions, Implementation of water meters, Leak detection program completed by the Town, Public education/outreach, Discussions with Town regarding overall capacity and upgrades (funding), Well pumping tests, Drilling new wells and building new	3	1



OPERATIONAL PLAN

Wasaga Beach Well Supply System

QEMS Doc.: OP-08A
 Rev Date: 2024-10-03
 Rev No: 12
 Pages: 10 of 20

SUMMARY OF RISK ASSESSMENT OUTCOMES

Reviewed by: Process & Compliance Technician

Approved by: Senior Operations Manager

Activity / Process Step	Ministry's Potential Hazardous Event/Hazard Reference # (see Table 4)	Description of Hazardous Event	Possible Outcome (Hazards)	Existing Control Measures	Likelihood	Consequence	Risk Value	CCP?
				Pumphouses, if required, Additional water storage, if required, Stand-by well (if operable), Permit to Take Water and Municipal Drinking Water License amendments to increase water taking/production limits, Using only a percentage of the capacity in the current License and Permits, annual reporting (i.e. Schedule 22 Summary Reports), council meetings to discuss capacity versus demands, Town coordinates Design Consultant to model water and fire flow, joint DWQMS management reviews. Addition of Sunnidale Booster Station Jenetta- Well 4 drilled and registered.				
			Decrease in fire protection	Water use restrictions / ban, Back-up Pumphouse, Back-up Tower, Communication procedures with Town and Fire Department, OCWA can provide On-site assistance for the fire department, if required, communications with the Fire Department. Nearby lakes and rivers that can be utilized for fire protection	2	4	8	<input checked="" type="checkbox"/> No
	3	Extreme Weather Events	Lack of access to facilities	Ongoing Capital upgrades – possible remote access to facility PLC, Agreement with Town and police for priority access, response, and/or escort, OERT, Standard Operating Procedures,	2	3	6	<input checked="" type="checkbox"/> No



OPERATIONAL PLAN
Wasaga Beach Well Supply System

QEMS Doc.: OP-08A
Rev Date: 2024-10-03
Rev No: 12
Pages: 11 of 20

SUMMARY OF RISK ASSESSMENT OUTCOMES

Reviewed by: Process & Compliance Technician

Approved by: Senior Operations Manager

Activity / Process Step	Ministry's Potential Hazardous Event/Hazard Reference # (see Table 4)	Description of Hazardous Event	Possible Outcome (Hazards)	Existing Control Measures	Likelihood	Consequence	Risk Value	CCP?
				Contingency Plan, Trained personnel, Staff located locally, communications with the Town Public Works department for snow removal and escort, if required.				
			Infrastructure damage	Redundancy in pumphouses, wells, chlorination systems, and towers, Asset management/rolling 10 year capital plans/ preventative maintenance. Discussions with Town for funding	2	2	4	<input checked="" type="checkbox"/> No
			Forest fires	On-call and communications procedures with Town and Fire Department, Staff availability, OERT, Grounds-keeping to reduce presence of flammable materials, Procedures to not store flammable materials at Pumphouses, Majority of building materials are non-flammable (concrete, brick, etc.), Towers – volume for fire protection, Jenetta Pumphouse located away from wooded areas, loss of power SOP, SCADA upgrades and access.	2	3	6	<input checked="" type="checkbox"/> No
	4	Sustained Extreme Temperatures	Frozen equipment and infrastructure (e.g. towers, services, mains, hydrants, etc.)	Requirement to run faucets / taps, Communications protocol with community / residents (for complaints & feedback), Heaters inside Pumphouses – temperature controlled, Trained personnel, Cooperation and coordination with Town and distribution	3	3	9	<input checked="" type="checkbox"/> No



OPERATIONAL PLAN
Wasaga Beach Well Supply System

QEMS Doc.: OP-08A
Rev Date: 2024-10-03
Rev No: 12
Pages: 12 of 20

SUMMARY OF RISK ASSESSMENT OUTCOMES

Reviewed by: Process & Compliance Technician

Approved by: Senior Operations Manager

Activity / Process Step	Ministry's Potential Hazardous Event/Hazard Reference # (see Table 4)	Description of Hazardous Event	Possible Outcome (Hazards)	Existing Control Measures	Likelihood	Consequence	Risk Value	CCP?
				crew – proper hydrant maintenance procedures, reduce hydrant usage where possible, etc., Plant checks by Operators, Additional monitoring of towers (for ice), Continuous monitoring, Alarms, Call-out, Secure premise around Towers. Access to rental heaters/furnaces.				
			Heat wave issues, staff vulnerabilities	Frequent work breaks, Hydration, Informing staff (H&S Topic), PPE policy, Wide range of PPE selection available to suit high temperatures yet still adhere to PPE policy, Restricted duties, Reduced work schedule (shorter days), Ice packs, etc., Ability to seek shelter in pumphouses and/or trucks, bottled water, Manager's direction	4	2	8	<input checked="" type="checkbox"/> No

Table 2: Identified Critical Control Points (CCPs)

CCP	Critical Control Limits	Monitoring Procedures	Response, Reporting and Recording Procedures
Primary Disinfection: Sodium Hypochlorite System	Free Chlorine Residual: <u>Jenetta Pumphouse</u> Please refer to posted CT calculation to calculate the minimum free chlorine residual needed to meet CT based on the actual flow rate from the wells.	<ul style="list-style-type: none"> Plant Inspections (weekdays) Continuous monitoring Alarm Systems 	<u>Jenetta Pumphouse:</u> <ul style="list-style-type: none"> Low Chlorine Alarm SOP Low Chlorine Residual Alarm at Jenetta Street Pumphouse (Facility Emergency Plan) SOP for Determining 2-log Removal of Viruses "CT – Has the treated



OPERATIONAL PLAN
Wasaga Beach Well Supply System

QEMS Doc.: OP-08A
Rev Date: 2024-10-03
Rev No: 12
Pages: 13 of 20

SUMMARY OF RISK ASSESSMENT OUTCOMES

Reviewed by: Process & Compliance Technician

Approved by: Senior Operations Manager

CCP	Critical Control Limits	Monitoring Procedures	Response, Reporting and Recording Procedures
	<p><u>Powerline Pumphouse</u> Please refer to posted CT chart for Scenario 1: Normal Operations or Scenario 2: Reservoir isolated from Clear Wells.</p> <p>The minimum chlorine residual (mg/L) or critical control limit needed to meet Primary Disinfection is dependent on conditions during a low chlorine incident that being the depth of the reservoir (m) and distribution high lift pumping (L/s).</p>		<p>water directed to consumers been properly disinfected?"</p> <ul style="list-style-type: none"> Logbook entry Back-flushing contact main <p><u>Powerline Pumphouse:</u></p> <ul style="list-style-type: none"> Low Chlorine Alarm SOP Primary Disinfection at Powerline Road (Facility Emergency Plan) SOP for Determining 2-log Removal of Viruses "CT – Has the treated water directed to consumers been properly disinfected?" Logbook entry
<p>Secondary Disinfection: Sodium Hypochlorite System</p>	<p>Free Chlorine Residual: 0.05 mg/L in distribution system</p>	<ul style="list-style-type: none"> Distribution chlorine residuals monitored as per O. Reg. 170/03 via Distribution Chlorine Residual Analyzer at Wasaga Beach Wastewater Lab Treated Chlorine Residual Analyzers at pumphouses Weekly grab distribution samples for bacteriological testing; free and total chlorine measured Residuals taken during flushing by Town Staff Additional Sunnidale Booster Station 	<ul style="list-style-type: none"> Low Distribution Chlorine SOP Logbook entry Alarmed online distribution system analyzers Additional manual/grab distribution samples (4 & 3 as per O. Reg 170/03) if needed and distribution sample data sheet page. Reporting to Ministry, etc.



OPERATIONAL PLAN
Wasaga Beach Well Supply System

QEMS Doc.: OP-08A
Rev Date: 2024-10-03
Rev No: 12
Pages: 14 of 20

SUMMARY OF RISK ASSESSMENT OUTCOMES

Reviewed by: Process & Compliance Technician

Approved by: Senior Operations Manager

Note: Standard Operating Procedures (SOPs) referenced in Tables 1 and 2 are controlled as per OP-05 Document and Records Control.

Table 3: Record of Annual Review/36-Month Risk Assessment

The Drinking Water Quality Management Standard (DWQMS) requires that the currency of the information and the validity of the assumptions used in the risk assessment be verified at least once every calendar year. In addition, the risk assessment must be conducted at least once every thirty-six months.

Date of Activity (YYYY-MM-DD)	Type of Activity	Participants	Summary of Results
2008-07-29	Initial risk assessment conducted.		Creation of Risk Assessment for the Wasaga Beach Well Supply System.
2012-05-09	Joint Management Review Meeting decision to review and revise the critical control points limits.	Decision by: OCWA committee members Richard Junkin (Senior Operations Manager & QEMS Rep), Karen Lorente (Operations Manager), Doug Macham (ORO OCWA Operator) and Rick Sorge (PCT & QEMS Rep). Review by: Doug Macham, Terry Cameron, Zac Osso, Paul Yandt, Karen Lorente, Richard Junkin, Amy Wilson and Rick Sorge	Reviewed and revised the "Summary of Risk Assessment Outcomes" with changes to the "risk value" of the following hazardous events: well casing collapse, tower low pressure, reservoir low level, loss of generator at one of the pumphouses and entire system power failure.
2015-05-05	3-year Risk Assessment Review	Karen Lorente (Senior Operations Manager & QEMS Rep), Sheri Broeckel (Operations Manager), Richard Eagle (PCT), Doug Macham (ORO Water & OCWA Operator), Terry Cameron (ORO Waste & Operator), Rob Gucsma (Operator), Jason Perry (Co-op Student) and Rick Sorge (PCT & QEMS Rep)	Reviewed and revised the "Summary of Risk Assessment Outcomes" with changes to the "risk value of the following hazardous events: well casing collapse, chemical spill, high level on tower, high level on reservoir, loss of communication on control system, and added the loss of communication between Powerline and Jenetta pumphouses.
2018-05-02	3-year Risk Assessment Review and inclusion of	Troy Backhaus (Operator), Terry Cameron (Senior Operator), Richard	Revisions made to all hazardous events and updated likelihood and consequence for each hazardous event. New



OPERATIONAL PLAN
Wasaga Beach Well Supply System

QEMS Doc.: OP-08A
Rev Date: 2024-10-03
Rev No: 12
Pages: 15 of 20

SUMMARY OF RISK ASSESSMENT OUTCOMES

Reviewed by: Process & Compliance Technician

Approved by: Senior Operations Manager

Date of Activity (YYYY-MM-DD)	Type of Activity	Participants	Summary of Results
	New Hazardous Events as per DWQMS 2.0	Eagle (Senior Operations Manager), Michelle Neal (Operator), and Robyn Waher (PCT & QEMS Rep)	hazardous events were added as per DWQMS 2.0 requirements and risk values were assigned for each new potential outcome. All of the hazardous events have been numbered for ease of reference and when repetition is observed. "Long term impacts of Climate Change" added as a new CCP in Table 2.
2019-05-23	Annual Risk Assessment Review	Troy Backhaus (Operator), Terry Cameron (Senior Operator), Richard Eagle (Senior Operations Manager), and Robyn Waher (PCT & QEMS Rep)	Reviewed and revised Table 1 with the latest "existing control measures" for each hazardous event. Reflects latest configuration. Some items were removed as they no longer applied, but most of the items were new because of upgrades, recent changes, additional information, knowledge of the Town's operations, recent call-ins and troubleshooting exercises, budget discussions with the Town, and DWQMS management reviews. Updates made to Table 2 with respect to the Response, Reporting and Recording Procedures and the monitoring activities for the CCP's.
2020-09-03	Annual Risk Assessment Review	Troy Backhaus (Operator) and David Jorge (PCT & QEMS Rep)	Reviewed and revised Table 1 with the latest "existing control measures" for each hazardous event. Reflects latest configuration. Changes to Sudden changes to raw water characteristics, Chemical feed pump failure, Reservoir low level, Loss of communication with Huronia Alarms, Loss of communication between Powerline and Jenetta, Water Supply Shortfall. Minor adjustments to descriptions. Secondary disinfection had Town staff residuals added occurring during flushing procedures.
2021-10-21	3-year Risk Assessment Review	Richard Eagle (Senior Operations Manager), Troy Backhaus (Operator), Kristen Tilotta (PCT & QEMS Rep), David Jorge (PCT & QEMS Rep)	Reviewed and revised Table 1 with the latest "existing control measures" for each hazardous event. Reflects latest configuration. Changes to Control System- Loss of automatic controls at Jenetta pumphouse, Facility Security- Vandalism, Cyber Terrorism and Confrontation, Long Term Impacts of Climate Change- Increase/decrease in water levels in lakes and aquifers, and Water Supply Shortfall- Increase in water demand due to increase in population. Adjustments made to



OPERATIONAL PLAN
Wasaga Beach Well Supply System

QEMS Doc.: OP-08A
Rev Date: 2024-10-03
Rev No: 12
Pages: 16 of 20

SUMMARY OF RISK ASSESSMENT OUTCOMES

Reviewed by: Process & Compliance Technician

Approved by: Senior Operations Manager

Date of Activity (YYYY-MM-DD)	Type of Activity	Participants	Summary of Results
			Existing Control Measures. Minor update made to Table 2 with respect to Monitoring Procedures for Secondary Disinfection Sodium Hypochlorite System: Inclusion of Sunnidale Booster Station.
2022-05-31	Annual Risk Assessment Review	Richard Eagle (Senior Operations Manager) and Kristen Tilotta (PCT & QEMS Rep)	Reviewed and revised Table 1 with the latest “existing control measures” for each hazardous event. Reflects latest configuration, changes made to Jenetta chart recorders now being digital.
2023-06-28	Annual Risk Assessment Review	Richard Eagle (Senior Operations Manager), Kristen Tilotta (Acting Safety, Process and Compliance Manager) and Angela Pauze (PCT/Operator)	Reviewed and revised Table 1 with the latest “existing control measures” for each hazardous event. Reflects latest configuration. Changes made to/added “Potential Hazardous Events for Municipal Residential Drinking Water Systems” dated April 2022 (cybersecurity threats is already found within Table 2 under “Facility Security”, added to Table 4 as well) Added Cybersecurity threats to Table 4 (new Ministry requirements); updated revision date of Ministry’s document “Potential Hazardous Events for Municipal Residential Drinking Water Systems” to April 2022 (previously February 2017); Linked Table 1 to Table 4 Cybersecurity threats. Revision to “Raw Water Characteristic/Well- Sudden changes to characteristics to include responding to community complaints. Updated existing measures for “Primary Disinfection- Chlorine Analyzer Failure”- to include the spare analyzer at Powerline Pumphouse. Under “Control System-Loss of Communication” updated existing control measure to include that Jenetta and Powerline Pumphouses can be operated manually and independently from one another, Under “Partial System-Generator Failure” updated existing control measure that account for the Vendor of Records for generator repairs and rental access. Under “All systems- long tern impact of climate change” added Hydrogeological studies conducted on a 5 year assessment for PTTW renewals to control measures.



OPERATIONAL PLAN
Wasaga Beach Well Supply System

QEMS Doc.: OP-08A
Rev Date: 2024-10-03
Rev No: 12
Pages: 17 of 20

SUMMARY OF RISK ASSESSMENT OUTCOMES

Reviewed by: Process & Compliance Technician

Approved by: Senior Operations Manager

Date of Activity (YYYY-MM-DD)	Type of Activity	Participants	Summary of Results
			Under "All- decrease in fire protection" added to control measures for Nearby lakes and rivers that can be utilized for fire protection. Under "All-sustained extreme frozen temperatures" added access to rental heaters/furnaces. Under "CPP-Primary Disinfection" added Back-flushing contact main as a response. Under "CPP- Secondary Disinfection" added Alarmed online distribution system analyzers and Additional manual/grab distribution samples (4 & 3 as per O. Reg 170/03) if needed and distribution sample data sheet page as responses.
2024-10-03	36 Month Risk Assessment Review	Colin Kasperavicius (Senior Operations Manager), Dustin Trace (Operations Supervisor) and Kristen Tilotta (Georgian Highlands Region SPC Manager (A))	Reviewed and revised Table 1 with the latest "existing control measures" for each hazardous event. Reflects latest configuration. Changes made to control systems- Loss of Communication with Huronia Alarms: removed reference to OCWA panel program and added cellphone dialers. Changes made to control system- Loss of Communication between Powerline and Jenetta Pumphouses- rescoring. Added to existing control measures for Entire System- No Diesel Fuel Supply- Loss of diesel back-up power: added TSSA upgrades. Under Facility- Cyber terrorism: added OCWA MFA. Under Facility security- Chemical / bacteriological contamination- removed reference to Powerline being surrounded by residential homes. Under All systems- Long term impacts of climate change- high winds/tornados- removed reference to "Corporate- weather warnings/watches". Overall: general reformatting, grammer corrections and rewordings. Updated all references of MECP to "Ministry".



OPERATIONAL PLAN
Wasaga Beach Well Supply System

QEMS Doc.: OP-08A
Rev Date: 2024-10-03
Rev No: 12
Pages: 18 of 20

SUMMARY OF RISK ASSESSMENT OUTCOMES

Reviewed by: Process & Compliance Technician

Approved by: Senior Operations Manager

Table 4: Potential Hazardous Event/Hazard Reference Numbers (based on the Ministry’s “Potential Hazardous Events for Municipal Residential Drinking Water Systems,” dated April 2022)

If the hazardous event/hazard is not applicable to this drinking water system (DWS), it will be noted in the first column of this table.

System Type (indicate with an X all that apply to this DWS)		Reference Number	Description of Hazardous Event/Hazard
X	All Systems	1	Long Term Impacts of Climate Change
X	All Systems	2	Water supply shortfall
X	All Systems	3	Extreme weather events (e.g., tornado, ice storm)
X	All Systems	4	Sustained extreme temperatures (e.g., heat wave, deep freeze)
X	All Systems	5	Chemical spill impacting source water
X	All Systems	6	Terrorist and vandalism actions
X	Distribution Systems	7	Sustained pressure loss
X	Distribution Systems	8	Backflow
X	Treatment Systems	9	Sudden changes to raw water characteristics (e.g., turbidity, pH)
X	Treatment Systems	10	Failure of equipment or process associated with primary disinfection (e.g., coagulant dosing system, filters, UV system, chlorination system)
X	Treatment Systems and Distribution Systems providing secondary disinfection	11	Failure of equipment or process associated with secondary disinfection (e.g., chlorination equipment, chloramination equipment)
N/A ¹	Treatment Systems using Surface Water	12	Algal blooms
X	All Systems	13	Cybersecurity threats

N/A¹: “Algal Blooms” Hazardous Event does not apply. Source water is groundwater within this Drinking Water System.

Revision History

Date	Revision #	Reason for Revision
2008-07-29	0	Initial risk assessment conducted.



OPERATIONAL PLAN
Wasaga Beach Well Supply System

QEMS Doc.: OP-08A
Rev Date: 2024-10-03
Rev No: 12
Pages: 19 of 20

SUMMARY OF RISK ASSESSMENT OUTCOMES

Reviewed by: Process & Compliance Technician

Approved by: Senior Operations Manager

Date	Revision #	Reason for Revision
2012-05-09	1	Joint Management Review Meeting (16-Apr-12) – decision by OCWA committee members Richard Junkin (Senior Operations Manager & QEMS Rep), Karen Lorente (Operations Manager), Doug Macham (ORO OCWA Operator) and Rick Sorge (PCT & QEMS Rep) to review and revise the critical control points limits. OCWA Wasaga Beach Group Operations Staff Meeting (09-May-12) decision by staff (Doug Macham, Terry Cameron, Zac Osso, Paul Yandt, Karen Lorente, Richard Junkin, Amy Wilson and Rick Sorge) to review and revise the “Summary of Risk Assessment Outcomes” with changes to the “risk value” of the following hazardous events: well casing collapse, tower low pressure, reservoir low level, loss of generator at one of the pumphouses and entire system power failure.
2015-05-05	2	OCWA Wasaga Beach Group Operations Staff Meeting (05-May-15) attended by Karen Lorente (Senior Operations Manager & QEMS Rep), Sheri Broeckel (Operations Manager), Richard Eagle (PCT), Doug Macham (ORO Water & OCWA Operator), Terry Cameron (ORO Waste & Operator), Rob Gucsma (Operator), Jason Perry (Co-op Student) and Rick Sorge (PCT & QEMS Rep) reviewed and revised the “Summary of Risk Assessment Outcomes” with changes to the “risk value of the following hazardous events: well casing collapse, chemical spill, high level on tower, high level on reservoir, loss of communication on control system, and added the loss of communication between Powerline and Jenetta pumphouses.
2018-05-04	3	3-year Risk Assessment Review completed by Troy Backhaus (Operator), Terry Cameron (Senior Operator), Richard Eagle (Senior Operations Manager), Michelle Neal (Operator), and Robyn Waher (PCT & QEMS Rep) on May 2, 2018 – revisions made to all hazardous events and updated likelihood and consequence for each hazardous event. New hazardous events were added as per DWQMS 2.0 requirements and risk values were assigned for each new potential outcome. All of the hazardous events have been numbered for ease of reference and when repetition is observed. “Long term impacts of Climate Change” added as a new CCP in Table 2.
2018-06-21	4	Summary of Risk Assessment Outcomes updated to reflect new Corporate Compliance template. Assigned document number (OP-08A) and added table 3 to record when the Annual Reviews or 36-Month Risk Assessment Reviews take place, outline the participants, and provide a summary of results.
2019-03-12	5	Updated Risk Assessment to reflect latest Corporate Compliance template, e.g. addition of Table 4, etc. Changed MOECC to MECF. Added “Secondary Disinfection” to Distribution Activity/Process Step in Table 1 in order to be consistent with Table 2 (as per Internal Audit 2018-10-31). Removed “Drought/Flood” Hazardous Event from CCP Table 2 due to the fact it cannot be controlled and also does not meet the criteria outlined in OP-07 3.3.7 (as per External Audit 2019-02-08).
2019-05-23	6	Annual Risk Assessment Review. Updates made to Table 1 with the latest “existing control measures” for each hazardous event. Reflects latest configuration. Some items were removed as they no longer



OPERATIONAL PLAN

Wasaga Beach Well Supply System

QEMS Doc.: OP-08A
Rev Date: 2024-10-03
Rev No: 12
Pages: 20 of 20

SUMMARY OF RISK ASSESSMENT OUTCOMES

Reviewed by: Process & Compliance Technician

Approved by: Senior Operations Manager

Date	Revision #	Reason for Revision
		applied, but most of the items were new because of upgrades, recent changes, additional information, knowledge of the Town's operations, recent call-ins and troubleshooting exercises, budget discussions with the Town, and DWQMS management reviews. Updates made to Table 2 with respect to the Response, Reporting and Recording Procedures for the primary and secondary disinfection CCP's and the monitoring activities for the secondary disinfection CCP.
2020-09-24	7	Annual Risk Assessment Review. Updates made to Table 1 with the latest "existing control measures" for each hazardous event. Reflects latest configuration. See Table 3 for additional details.
2021-10-22	8	36-Month Risk Assessment Review completed by Troy Backhaus (Operator), Richard Eagle (Senior Operations Manager), David Jorge (PCT & QEMS Rep) and Kristen Tilotta (PCT & QEMS Rep) on October 21 st , 2021. Updates made to Table 1 with the latest "existing control measures" for each hazardous event. Reflects latest configuration. See Table 3 for additional details.
2022-05-31	9	Annual Risk Assessment Review completed by Richard Eagle (Senior Operations Manager), and Kristen Tilotta (PCT/QEMS Rep) on May 31 st , 2022. Reviewed and revised Table 1 with the latest "existing control measures" for each hazardous event. Reflects latest configuration. See Table 3 for additional details.
2023-06-28	10	Annual Risk Assessment Review completed by Richard Eagle (Senior Operations Manager), Angela Pauze (PCT/QEMS Rep) and Kristen Tilotta (SPCM(A)) on June 28, 2023. Reviewed and revised Table 1 with the latest "existing control measures" for each hazardous event. Reflects latest configuration. See Table 3 for additional details on changes made.
2024-08-20	11	Changed Table 4 reference number 11 from "NA" to "X", secondary disinfection is maintained with free chlorine.
2024-10-03	12	36-Month Risk Assessment Review completed by Dustin Trace (Operations Supervisor), Colin Kasperavicius (Senior Operations Manager), and Kristen Tilotta (Georgian Highlands SPC Manager (A)) on October 03, 2024. Updates made to Table 1 with the latest "existing control measures" and rescoring of likelihood, consequence and risk value (as applicable) for each hazardous event. Reflects latest configuration. See Table 3 for additional details.



OPERATIONAL PLAN

Wasaga Beach Well Supply System

QEMS Proc.: OP-09
Rev Date: 2024-08-20
Rev No: 6
Pages: 1 of 7

ORGANIZATIONAL STRUCTURE, ROLES, RESPONSIBILITIES AND AUTHORITIES

Reviewed by: Process & Compliance Technician

Approved by: Senior Operations Manager

1. Purpose

To document the following for the Wasaga Beach Well Supply System:

- Owner;
- Organizational structure of the Operating Authority;
- QEMS roles, responsibilities and authorities of staff, Top Management and individuals/groups that provide corporate oversight; and
- Responsibilities for conducting the Management Review

2. Definitions

Operations Management – refers to the General Manager, Senior Operations Manager and/or Operations Manager that directly oversees a facility's operations

Senior Leadership Team (SLT) – members include President and CEO, Executive Vice President and General Counsel, Vice Presidents of OCWA's business units and Regional Hub Managers

Top Management – a person, persons or a group of people at the highest management level within an operating authority that makes decisions respecting the QMS and recommendations to the owner respecting the subject system or subject systems

Operations Personnel – Employees of the drinking water system who perform various activities related to the compliance, operations and maintenance of the drinking water system that may directly affect drinking water quality

3. Procedure

3.1 Organizational Structure

The Wasaga Beach Well Supply System is owned by the Corporation of the Town of Wasaga Beach and is represented by the Director of Public Works and CAO.

The organizational structure of OCWA, the Operating Authority, is outlined in appendix OP-09A: Organizational Structure.

3.2 Top Management

Top Management for the Wasaga Beach Well Supply System consists of:

- Senior Operations Manager – Georgian Bay Hub
- Regional Hub Manager – Georgian Highlands Region
- Safety, Process & Compliance Manager – Georgian Highlands Region

Irrespective of other duties (see Table 9-2 below), Top Management's responsibilities and authorities include:



OPERATIONAL PLAN
Wasaga Beach Well Supply System

QEMS Proc.: OP-09
Rev Date: 2024-08-20
Rev No: 6
Pages: 2 of 7

ORGANIZATIONAL STRUCTURE, ROLES, RESPONSIBILITIES AND AUTHORITIES

Reviewed by: Process & Compliance Technician Approved by: Senior Operations Manager

- Endorsing the Operational Plan as per the Commitment and Endorsement procedure (OP-03);
- Ensuring that the QEMS meets the requirements of the DWQMS;
- Ensuring staff are aware of the applicable legislative and regulatory requirements;
- Communicating the QEMS according to the Communications procedure (OP-12);
- Providing resources needed to maintain and continually improve the QEMS;
- Appointing and authorizing a QEMS Representative (OP-04); and
- Undertaking Management Reviews as per the Management Review procedure (OP-20).

Note: Specific responsibilities of the individual members of Top Management are identified in the referenced procedures.

3.3 Corporate Oversight

Roles, responsibilities and authorities for individuals/groups providing corporate oversight of OCWA's QEMS are summarized in Table 9-1 below.

Table 9-1: Corporate QEMS Roles, Responsibilities and Authorities

Role	Responsibilities and Authorities
Board of Directors	<ul style="list-style-type: none"> • Set the Agency's strategic direction, monitor overall performance and ensure appropriate systems and controls are in place in accordance with the Agency's governing documents • Review and approve the QEMS Policy
Senior Leadership Team (SLT)	<ul style="list-style-type: none"> • Establish the Agency's organizational structure and governing documents and ensure resources are in place to support strategic initiatives • Monitor and report on OCWA's operational and business performance to the Board of Directors • Review the QEMS Policy and recommend its approval to the Board • Approve corporate QEMS programs and procedures
Corporate Compliance	<ul style="list-style-type: none"> • Manage the QEMS Policy and corporate QEMS programs and procedures • Provide support for the local implementation of the QEMS • Monitor and report on QEMS performance and any need for improvement to SLT • Consult with the Ministry and other regulators and provide compliance support/guidance on applicable legislative, regulatory and policy requirements • Manage contract with OCWA's DWQMS accreditation body



OPERATIONAL PLAN
Wasaga Beach Well Supply System

QEMS Proc.: OP-09
Rev Date: 2024-08-20
Rev No: 6
Pages: 3 of 7

ORGANIZATIONAL STRUCTURE, ROLES, RESPONSIBILITIES AND AUTHORITIES

Reviewed by: Process & Compliance Technician Approved by: Senior Operations Manager

3.4 Regional Hub Roles, Responsibilities and Authorities

QEMS roles, responsibilities and authorities of Regional Hub personnel are summarized in Table 9-2 below. This information is kept current as per the Document and Records Control procedure (OP-05) and is communicated to staff as per the Communications procedure (OP-12).

Additional duties of employees are detailed in their job specifications and in the various QEMS programs and procedures that form, or are referenced in, this Operational Plan.

Table 9-2: QEMS Roles, Responsibilities and Authorities for the Georgian Highlands Region

Role/Position	Responsibilities and Authorities
All Operations Personnel	<ul style="list-style-type: none"> • Perform duties in compliance with applicable legislative and regulatory requirements • Be familiar with the QEMS Policy and work in accordance with QEMS programs and procedures • Maintain operator certification (as required) • Attend/participate in training relevant to their duties under the QEMS • Document all operational activities • Identify potential hazards at their facility that could affect the environmental and/or public health and report to Operations Management • Report and act on all operational incidents • Recommend changes to improve the QEMS
Regional Hub Manager (Top Management)	<ul style="list-style-type: none"> • Oversee the administration and delivery of contractual water/wastewater services on a Regional Hub level • Fulfill role of Top Management • Ensure corporate QEMS programs and procedures are implemented consistently throughout the Regional Hub • Manages the planning of training programs for Regional Hub • Report to VP of Operations/SLT on the regional performance of the QEMS and any need for Agency-wide improvement
Operations Management (Top Management)	<ul style="list-style-type: none"> • Manage the day-to-day operations and maintenance of their assigned facilities and supervise facility operational staff • Fulfill role of Top Management • Ensure corporate and site-specific QEMS programs and procedures are implemented at their assigned facilities • Determine necessary action and assign resources in response to operational issues • Report to the Regional Hub Manager on facility operational performance



Ontario Clean Water Agency

OPERATIONAL PLAN

Wasaga Beach Well Supply System

QEMS Proc.: OP-09
Rev Date: 2024-08-20
Rev No: 6
Pages: 4 of 7

ORGANIZATIONAL STRUCTURE, ROLES, RESPONSIBILITIES AND AUTHORITIES

Reviewed by: Process & Compliance Technician Approved by: Senior Operations Manager

Role/Position	Responsibilities and Authorities
	<ul style="list-style-type: none"> • Ensure operational training is provided for the cluster (in consultation with the SPC Manager as required) • Act as Overall Responsible Operator (ORO) when required (WDS III and/or WWTIII certification required).
<p>Safety, Process & Compliance (SPC) Manager (Top Management)</p>	<ul style="list-style-type: none"> • Supervise facility compliance staff and provide technical and program support to the Regional Hub related to process control and compliant operations • Fulfill role of Top Management • Ensure corporate/regional QEMS programs and procedures are implemented consistently throughout the Regional Hub • Assist in the development of site-specific operational procedures as required • Ensure training on applicable legislative and regulatory requirements and the QEMS is provided for the Regional Hub (in consultation with Operations Management as required) • Monitor and report to the Regional Hub Manager and Operations Management on the compliance status and QEMS performance within his/her Regional Hub and any need for improvement • Act as alternate QEMS Representative (when required) • May act as Operator-in-Charge (OIC) and/or ORO when required (WDS III and/or WWTIII certification required for ORO, WDS I and/or WWT I required for OIC).
<p>Process & Compliance Technician (PCT) / (QEMS Representative)</p>	<ul style="list-style-type: none"> • Implement, monitor and support corporate programs relating to environmental compliance and support management by evaluating and implementing process control systems at their assigned facilities • Fulfill role of QEMS Representative (OP-04) • Monitor, evaluate and report on compliance/quality status of their assigned facilities • Implement facility-specific QEMS programs and procedures consistently at their assigned facilities • Participate in audits and inspections and assist in developing, implementing and monitoring action items to respond to findings • Report to the SPC Manager on QEMS implementation and identify the need for additional/improved processes and procedures at the Regional Hub/cluster/facility level (in consultation with the Operations Management as required) • Communicates to Owners on facility compliance and DWQMS accreditation as directed • Deliver/participate in/coordinate training including applicable legislative and regulatory requirements and the QEMS • May fulfil role of Certified Operator when required (minimum OITs required)



Ontario Clean Water Agency

OPERATIONAL PLAN

Wasaga Beach Well Supply System

QEMS Proc.: OP-09
Rev Date: 2024-08-20
Rev No: 6
Pages: 5 of 7

ORGANIZATIONAL STRUCTURE, ROLES, RESPONSIBILITIES AND AUTHORITIES

Reviewed by: Process & Compliance Technician Approved by: Senior Operations Manager

Role/Position	Responsibilities and Authorities
<p>Certified Operator</p> <p>May include the following positions:</p> <ul style="list-style-type: none"> • Operations Supervisor Water & Wastewater • Water & Wastewater Lead • Senior Water & Wastewater Operator • Water & Wastewater Operator • Water & Wastewater Operator-In-Training (OIT)] 	<ul style="list-style-type: none"> • Perform duties outlined under Operations Personnel • Monitor, maintain and operate facilities in accordance with applicable regulations, approvals and established operating procedures • Collect samples and perform laboratory tests and equipment calibrations as required • Regularly inspect operating equipment, perform routine preventive maintenance and repairs and prepare and complete work orders as assigned • Ensure records of adjustments made to the process under their responsibility, equipment operating status during their shifts and any departures from normal operations observed and actions taken are maintained within facility logs/record keeping mechanisms (as per O. Reg. 128) • Participate in facility inspections and audits May act as Operator-in-Charge (OIC) and/or ORO when required (WDS III and/or WWTIII certification required for ORO, WDS I and/or WWT I required for OIC). <p>NOTE: OITs cannot act as OIC and/or ORO. OITs perform the above duties under the direction of the OIC/ORO and as assigned by Operations Management or designate.</p>
<p>Maintenance Personnel</p> <p>May include the following positions:</p> <ul style="list-style-type: none"> • Mechanic/Operator • Maintenance Technician • Maintenance Shift Lead • Senior Water & Wastewater Operator, etc.] 	<ul style="list-style-type: none"> • Schedule and perform maintenance on equipment and processes in accordance with established procedures and record the maintenance data • Regularly inspect operating equipment, perform routine preventive maintenance and repairs • May fulfill role of Certified Operator when required (based on certification).
<p>Instrumentation Technician</p> <p>May include the following positions:</p> <ul style="list-style-type: none"> • Utility Plant Instrument Technician (UPIT) • Utility Plant Electrician Operator 	<ul style="list-style-type: none"> • Provide advice and technical expertise on the services required for process control and automation systems • Discuss and advise on detailed system and programming requirements, modify existing and new software in response to plant requests, analyze and resolve problems/error conditions, document changes/modifications and configure, install and support related software, hardware and network for such systems • Conduct inspections of the process control and automation systems to validate that all is operating within established parameters as requested



Ontario Clean Water Agency

OPERATIONAL PLAN

Wasaga Beach Well Supply System

QEMS Proc.: OP-09
Rev Date: 2024-08-20
Rev No: 6
Pages: 6 of 7

ORGANIZATIONAL STRUCTURE, ROLES, RESPONSIBILITIES AND AUTHORITIES

Reviewed by: Process & Compliance Technician | Approved by: Senior Operations Manager

Role/Position	Responsibilities and Authorities
<ul style="list-style-type: none"> Instrumentation Technician Operations Supervisor Water & Wastewater, etc. 	<ul style="list-style-type: none"> Install and commission new electrical/electronic equipment and automation systems May fulfill role of Certified Operator as required (based on certification).
<p>Electrical Maintenance Personnel</p> <p>May include the following positions:</p> <ul style="list-style-type: none"> Utility Plant Electrician Operator Maintenance Electrician Electrician Shift Lead etc.] 	<ul style="list-style-type: none"> Perform repairs, inspections, preventive maintenance and/or scheduled maintenance on electrical systems, equipment, components and devices in accordance with established procedures and record the maintenance data Examine, trouble shoot and carry out systematic diagnostic testing of faults/failures, identification, assessment, repairs/service to equipment, fixtures and other electrical component May fulfill role of Certified Operator as required (based on certification)
Administrative Assistant/Project Clerk	<ul style="list-style-type: none"> Support the administrative functions of the regional hub/cluster/facility including coordinating delivery of training as directed Assist with entering operational data (including operational training records, process data and maintenance records) into the appropriate database as directed

4. Related Documents

- OP-03 Commitment and Endorsement
- OP-04 QEMS Representative
- OP-05 Document and Records Control
- OP-09A Organizational Structure
- OP-12 Communications
- OP-20 Management Review
- OCWA Position Descriptions/Job Specifications

5. Revision History

Date	Revision #	Reason for Revision
2018-05-25	0	Procedure issued – Information within OP-09 was originally set out in the main body of OCWA’s Operational Plan (last revision 7 dated 2016-06-22). New Purpose, Definitions, Procedure, Related Documents and separate Revision History sections. Added definitions for Operations Management and Operations Personnel and throughout procedure replaced ‘Senior Operations Manager’ references with ‘Operations Management’. Incorporated OCWA’s new org structure, including SPC



Ontario Clean Water Agency

OPERATIONAL PLAN

Wasaga Beach Well Supply System

QEMS Proc.: OP-09
Rev Date: 2024-08-20
Rev No: 6
Pages: 7 of 7

ORGANIZATIONAL STRUCTURE, ROLES, RESPONSIBILITIES AND AUTHORITIES

Reviewed by: Process & Compliance Technician Approved by: Senior Operations Manager

Date	Revision #	Reason for Revision
		Manager. Removed two levels of Top Management (e.g. Facility Level and Corporate level), instead Top Management is only at the facility level and corporate has been moved to Corporate oversight. Re-worded QEMS Roles, Responsibilities and Authorities for each position. Added QEMS Roles, Responsibilities and Authorities for Administrative Assistant/Project Clerk.
2019-03-25	1	Removed OCWA positions that were not applicable for these Drinking Water Systems (i.e. Operations & Compliance (O&C) Team Lead, Maintenance Electrician/Operator and Project Clerk) as per Adjala-Tosorontio Internal Audit (2018-08-30).
2021-04-28	2	Added Owner roles and responsibilities to Table 9-2
2022-01-19	3	Removed names of personnel in 3.1 Organizational Structure to account of any changes in staffing structure.
2022-03-25	4	“Owner Role” removed from OP9- Table 2 as per External Audit recommendation. This table only calls for the description of the Operating Authority’s roles. Confirmed that “Owner” is not listed in Table 2 of the Corporate Template.
2023-01-23	5	Removed reference to “MOECC” and updated to MECP under Table 9-1: Corporate QEMS Roles, Responsibilities and Authorities for the role of Corporate Compliance and responsibilities to “Consult with the MECP and other regulators and provide compliance support/guidance on applicable legislative, regulatory and policy requirements”
2024-08-20	6	Procedure updated with revisions to Table 9-2 as follows: Role/Position updated to clarify roles are performed by multiple positions, position titles updated, note added regarding OITs operating limitations. Updated that the Operations Management is represented by the Georgian Bay Hub (removed reference of North Simcoe Hub). Additional revisions include replaced MECP with Ministry, minor rewording and type-o’s, removed watermark.



Ontario Clean Water Agency

OPERATIONAL PLAN

Wasaga Beach Well Supply

QEMS Doc.: OP-09A
Rev Date: 2024-08-20
Rev No: 7
Pages: 1 of 2

ORGANIZATIONAL STRUCTURE

Reviewed by: Process & Compliance Technician

Approved by: Senior Operations Manager

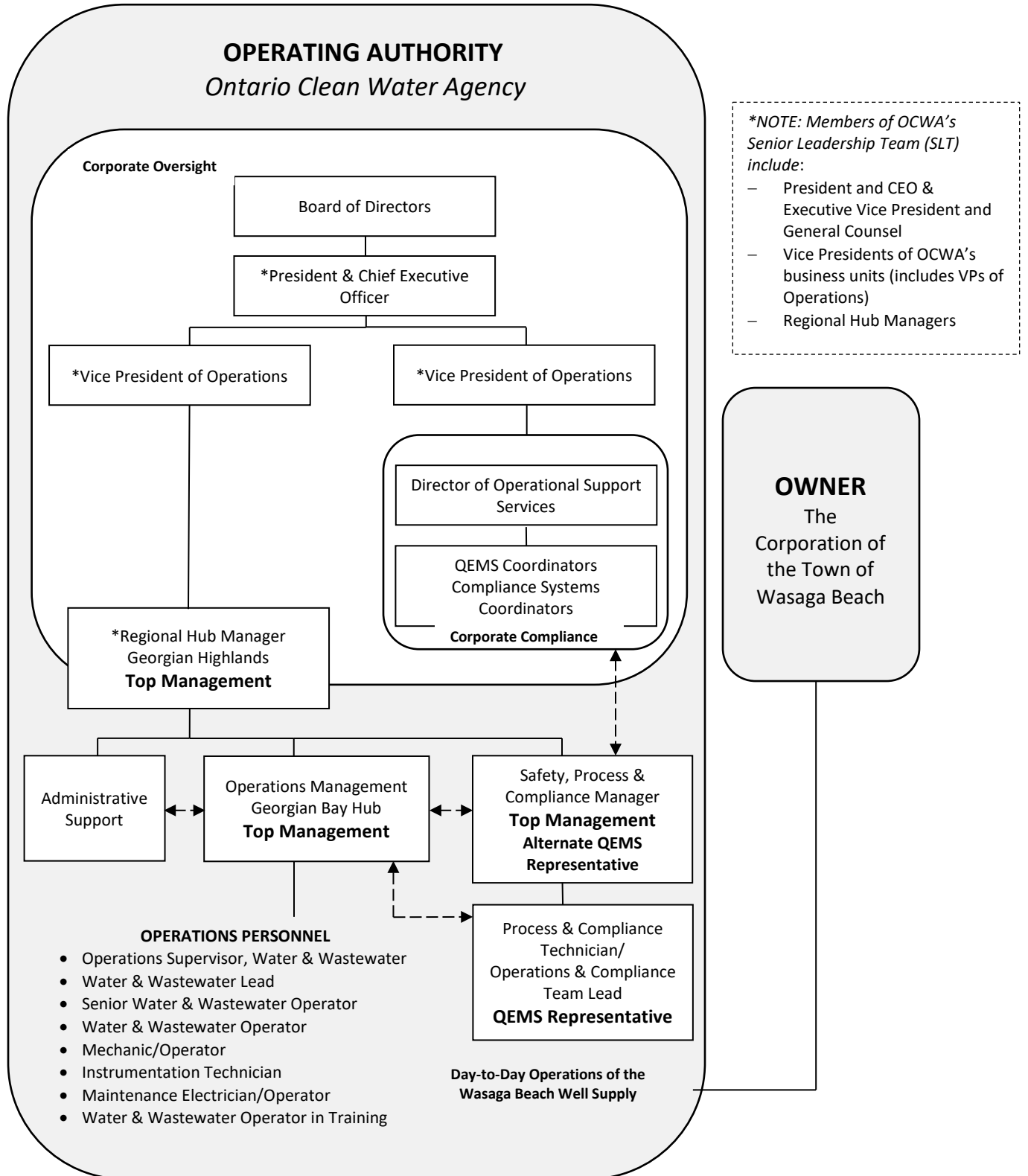



Ontario Clean Water Agency

OPERATIONAL PLAN

Wasaga Beach Well Supply

QEMS Doc.: OP-09A
Rev Date: 2024-08-20
Rev No: 7
Pages: 2 of 2

ORGANIZATIONAL STRUCTURE

Reviewed by: Process & Compliance Technician

Approved by: Senior Operations Manager

Revision History

Date	Revision #	Reason for Revision
2008-10-21	0	Appendix issued.
2012-04-26	1	Position Title Change: Operations Manager now Senior Operations Manager and Cluster Manager now Operations Manager
2014-11-10	2	Amend Appendices to remove specific names of Ontario Clean Water Agency Staff.
2018-05-25	3	Appendix issued following new template from Corporate Compliance. Organizational Chart was previously contained as Appendix C of the Operational Plan (last revision 7 dated 2016-06-22). Moved to Appendix OP-09A in new Operational Plan. New Revision History section. Incorporated OCWA's new org structure, including SPC Manager. Removed two levels of Top Management (e.g. Facility Level and Corporate level), instead Top Management is only at the facility level and corporate has been moved to Corporate oversight. Added Administrative Support.
2021-06-09	4	Revision to reflect change to reporting structure - Corporate Compliance now reports to VP of Operations.
2022-01-10	5	Removed reference to specific names for Regional Hub Manager to account for any future staffing changes
2023-01-23	6	Removed reference to "North Simcoe Hub" under Operations Management for the Top Management Representative and replaced with "Georgian Bay Hub" as the Town of Wasaga Beach is no longer part of OCWA- North Simcoe Hub.
2024-08-20	7	Revised to include Senior Leadership Team (SLT) in reporting structure and identify members, added Compliance System Coordinators, updated Operations Personnel position titles, removed watermark. Removed specific Regional Hub Manager's name and updated to "Georgian Highlands".



OPERATIONAL PLAN

Wasaga Beach Well Supply System

QEMS Proc.: OP-10
Rev Date: 2024-08-21
Rev No: 5
Pages: 1 of 6

COMPETENCIES

Reviewed by: Process & Compliance Technician | Approved by: Senior Operations Manager

1. Purpose

To document a procedure that describes:

- the competencies required for personnel performing duties directly affecting drinking water quality;
- the activities to develop and/or maintain those competencies; and
- the activities to ensure personnel are aware of the relevance of their duties and how they affect safe drinking water.

2. Definitions

Competence – the combination of observable and measurable knowledge, skills, and abilities which are required for a person to carry out assigned responsibilities

Operations Management – refers to the General Manager, Senior Operations Manager and/or Operations Manager that directly oversees a facility's operations

Operations Personnel – employees of the drinking water system who perform various activities related to the compliance, operations and maintenance of the drinking water system that may directly affect drinking water quality

Top Management – a person, persons or a group of people at the highest management level within an operating authority that makes decisions respecting the QMS and recommendations to the Owner respecting the subject system or subject systems

3. Procedure

3.1 The following table presents the minimum competencies required by operations personnel.

Role/Position	Required Minimum Competencies
Operations Management (Top Management)	<ul style="list-style-type: none">• Valid operator certification; if required to act as Overall Responsible Operator (ORO), WDS Class III and/or WWT Class III or higher• Experience and/or training in managing/supervising drinking water system operations, maintenance, financial planning and administration• Training and/or experience related to drinking water system processes, principles and technologies• Training on OCWA's QEMS and the DWQMS• Training on relevant legislation, regulations, codes, policies, guidelines and procedures• Experience using computers and operational computerized systems



OPERATIONAL PLAN

Wasaga Beach Well Supply System

QEMS Proc.: OP-10
 Rev Date: 2024-08-21
 Rev No: 5
 Pages: 2 of 6

COMPETENCIES

Reviewed by: Process & Compliance Technician | Approved by: Senior Operations Manager

Role/Position	Required Minimum Competencies
Safety, Process & Compliance (SPC) Manager (Top Management) (May also fulfill the role of Alternate QEMS Representative)	<ul style="list-style-type: none"> • Valid operator certification required to fulfil certified operator duties (if assigned). • Experience in providing technical support and leading/managing programs related to process control and compliant operations • Experience and/or training in conducting compliance audits, and management system audits • Experience and/or training in preparing and presenting informational and training material • Training on OCWA's QEMS and the DWQMS • Training on relevant legislation, regulations, codes, policies, guidelines and procedures • Experience using computers and operational computerized systems
Process & Compliance Technician, Operations and Compliance Team Lead (QEMS Representative)	<ul style="list-style-type: none"> • Valid operator certification if required to fulfil certified operator duties; minimum OIT • if required to act as Overall Responsible Operator (ORO), WDS Class III and/or WWT Class III or higher • Experience and/or training in resolving/addressing compliance issues for drinking water systems • Experience and/or training in monitoring, assessing and reporting on facility performance against legal requirements and corporate goals • Experience and/or training in preparing and presenting informational and training material • Experience in conducting management system audits or internal auditor education/training • Training on OCWA's QEMS and the DWQMS • Training on relevant legislation, regulations, codes, policies, guidelines and procedures • Experience using computers and operational computerized system
Certified Operator May include the following: <ul style="list-style-type: none"> • Operations Supervisor Water & Wastewater • Water & Wastewater Lead • Senior Water & Wastewater Operator • Water & Wastewater Operator • Water & Wastewater Operator-in-Training 	<ul style="list-style-type: none"> • Valid operator certification, minimum OIT • If required to act as ORO, certification must WDS Class III and/or WWT Class III or higher • If required to act as Operator-in-Charge (OIC), certification must be Class I or higher • Training and/or experience in inspecting and monitoring drinking water system processes and performing/planning maintenance activities • Training on OCWA's QEMS and the DWQMS • Training on relevant legislation, regulations, codes, policies, guidelines and procedures • Experience using computers and operational computerized systems



OPERATIONAL PLAN

Wasaga Beach Well Supply System

QEMS Proc.: OP-10
 Rev Date: 2024-08-21
 Rev No: 5
 Pages: 3 of 6

COMPETENCIES

Reviewed by: Process & Compliance Technician | Approved by: Senior Operations Manager

Role/Position	Required Minimum Competencies
<p>Maintenance Personnel</p> <p>May include the following:</p> <ul style="list-style-type: none"> • Mechanic/Operator • Maintenance Technician • Maintenance Shift Lead 	<ul style="list-style-type: none"> • Valid operator certification required; minimum OIT. • If required to act as ORO minimum level of WDS Class III and/or WWT Class III. • If required to act as Operator-in-Charge (OIC), certification must be Class I or higher • Millwright and/or other trades certificates (as applicable) • Experience in maintaining and repairing equipment and structures and in planning and scheduling maintenance and repair tasks • Training and/or experience related to drinking water system processes • Training on OCWA's QEMS and the DWQMS • Training on relevant legislation, regulations, codes, policies, guidelines and procedures • Experience using computers and operational computerized systems
<p>Instrumentation Technician</p> <p>May include the following:</p> <ul style="list-style-type: none"> • Utility Plant Instrument Technician • Instrumentation Technician • etc.] 	<ul style="list-style-type: none"> • Valid operator certification required; minimum OIT • If required to act as ORO minimum level of WDS Class III and/or WWT Class III. • If required to act as Operator-in-Charge (OIC), certification must be Class I or higher • Experience and/or training in monitoring, programming, installing and troubleshooting network, hardware, software and instrumentation • Experience and/or training in drinking water system processes, design, instrumentation, process control and automation systems • Training on OCWA's QEMS and the DWQMS • Training on relevant legislation, regulations, codes, policies, guidelines and procedures • Experience using computers and operational computerized systems
<p>Electrical Maintenance Personnel</p> <p>May include the following:</p> <ul style="list-style-type: none"> • Utility Plant Electrician Operator • Maintenance Electrician • Electrician Shift Lead etc.] 	<ul style="list-style-type: none"> • Valid operator certification required, minimum OIT (if assigned) • If required to act as ORO, WDS Class III and/or WWT Class III or higher • If required to act as Operator-in-Charge (OIC), certification must be Class I or higher • Training and/or experience in inspecting and monitoring drinking water system processes and performing/planning maintenance activities • Training on OCWA's QEMS and the DWQMS • Training on relevant legislation, regulations, codes, policies, guidelines and procedures • Experience using computers and operational computerized systems

COMPETENCIES

Reviewed by: Process & Compliance Technician | Approved by: Senior Operations Manager

3.2 The following table presents the minimum competencies required by staff that provide administrative support to operations personnel.

Role and/or Position	Required Minimum Competencies
Administrative Staff May include the following: - Administrative Assistant - Project Clerk	<ul style="list-style-type: none"> • Experience and/or training related to procurement and business administration practices • Training on OCWA's QEMS and the DWQMS • Training on relevant legislation, regulations, codes, policies, guidelines and procedures • Experience using computers

3.3 OCWA's recruiting and hiring practices follow those of the Ontario Public Service (OPS). As part of the OPS, minimum competencies, which include education, skills, knowledge and experience requirements, are established when designing the job description for a particular position. As part of the recruitment process, competencies are then evaluated against the job description. Based on this evaluation, the hiring manager selects and assigns personnel for specific duties.

3.4 OCWA's Operational Training Program aims to:

- Develop the skills and increase the knowledge of staff and management;
- Provide staff with information and access to resources that can assist them in performing their duties; and
- Assist OCWA certified operators in meeting the legislative and regulatory requirements with respect to training.

3.5 The Program consists of Director Approved, continuing education and on-the-job training and is delivered using a combination of methods (e.g., traditional classroom courses, e-learning/webinars and custom/program-based courses/sessions). A formal evaluation process is in place for all sessions under the Operational Training Program and is a critical part of the Program's continual improvement.

3.6 Awareness of OCWA's QEMS is promoted during the orientation of new staff, at facility/cluster/regional hub level training sessions and meetings and through OCWA's Environmental Compliance 101 (EC 101) course. All new staff are required to complete the EC 101 course within their first year of joining OCWA. The purpose of the EC 101 course is to ensure staff are aware of applicable legislative and regulatory requirements, to promote awareness of OCWA's QEMS and to reinforce their roles and responsibilities under OCWA's QEMS.

3.7 Staff are also required to complete the training listed in OCWA's Mandatory Training Requirements procedure, based on their position and/or the duties they perform. This list includes mandatory environmental and health and safety compliance training, as well as the training deemed mandatory by OCWA corporate and Ontario Public Service (OPS) policies and is available on OCWA's intranet (Sharepoint site).



OPERATIONAL PLAN

Wasaga Beach Well Supply System

QEMS Proc.: OP-10
Rev Date: 2024-08-21
Rev No: 5
Pages: 5 of 6

COMPETENCIES

Reviewed by: Process & Compliance Technician | Approved by: Senior Operations Manager

- 3.8 Operations personnel also receive site-specific training/instruction on relevant operational and emergency response procedures to ensure effective operational control of processes and equipment which may impact the safety and quality of drinking water.
- 3.9 As part of OCWA’s annual Performance Planning and Review (PPR) process, employee performance is evaluated against their job expectations. Professional development opportunities and training needs (which could include formalized courses as well as site-specific on-the-job training or job shadowing/mentoring) are identified as part of this process (and on an ongoing basis). In addition to this process, OCWA employees may at any time request training from either internal or external providers by obtaining approval from their Manager.
- 3.10 Certified drinking water operators are responsible for completing the required number of training hours in order to renew their certificates based on the highest class of drinking water subsystem they operate. They are also responsible for completing mandatory courses required by *Safe Drinking Water Act (SDWA) O. Reg. 128/04 Certification of Drinking Water System Operators and Water Quality Analysts*. The Operations Management takes reasonable steps to ensure that every operator has the opportunity to attend training to meet the requirements.
- 3.11 It is the responsibility of operations personnel to ensure Operations Management are aware of any change to the status/classification of their drinking water operator certificate(s), the validity of their driver’s license (required to hold at a minimum a Class G license which is initially verified upon hire) and/or the validity of any other required certificates/qualifications.
- 3.12 Individual OCWA employee training records are maintained and tracked using a computerized system, the Training Summary database, which is administrated by OCWA’s Learning and Development Department. Training records maintained at the facility are controlled as per OP-05 Document and Records Control.

4. Related Documents

- OCWA’s Learning and Development Resources (OCWA Intranet/Sharepoint)
- Orientation Checklists
- OCWA’s Mandatory Training Requirements (OCWA’s Sharepoint site)
- Performance Planning and Review Database
- OP-5 Document and Records Control
- OCWA Training Summary Database

5. Revision History

Date	Revision #	Reason for Revision
2018-05-25	0	Procedure issued – Information within OP-10 was originally set out in the main body of OCWA’s Operational Plan (last revision 7 dated 2016-06-22). New Purpose, Definitions, Procedure, Related Documents and



OPERATIONAL PLAN
Wasaga Beach Well Supply System

QEMS Proc.: OP-10
Rev Date: 2024-08-21
Rev No: 5
Pages: 6 of 6

COMPETENCIES

Reviewed by: Process & Compliance Technician | Approved by: Senior Operations Manager

Date	Revision #	Reason for Revision
		<p>separate Revision History sections. Added definitions for Operations Management and Operations Personnel and throughout procedure replaced 'Senior Operations Manager' references with 'Operations Management'. Modified table in procedure (s. 3.1 and s. 3.2): removed/revised non-measurable competencies, added the word 'minimum' to competencies; removed 'Valid Class G Driver's License' listed under individual positions and referenced in s. 3.11; added competencies for SPC Managers and Admin Assistants and merged competencies for Senior Operations Manager and Operations Manager under Operations Management. Updated training sections (s. 3.4 to s. 3.7) to reference new Environmental 101 course, Mandatory Compliance Training list and removed specific references to Orientation Training Program. Added s. 3.11 related to ensuring operators make Operations Management aware of changes to operator certification and other certificates/licenses. Other minor changes to wording.</p>
2019-03-12	1	<p>Added "valid certifications, if required" to Mechanic/Operator position as per Internal Audit (2018-10-31).</p>
2019-03-25	2	<p>Removed OCWA positions that were not applicable for these Drinking Water Systems (i.e. Operations & Compliance (O&C) Team Lead, Maintenance Electrician/Operator and Project Clerk) as per Adjala-Tosorontio Internal Audit (2018-08-30).</p>
2023-01-23	3	<p>Updated minimum operator certification requirements and minimum requirements to act as ORO for SPC Manager, Senior Operator/Mechanic, Operator/Mechanic and Mechanic/Operator.</p>
2024-02-05	4	<p>Removed reference to OCWA intranet and replaced with OCWA's Sharepoint Site.</p>
2024-08-21	5	<p>Procedure updated with revisions to table in 3.1 Role/Position updated to clarify roles are performed by multiple positions, position titles updated, removed watermark, updated Procedure to reflect changes to title and content of OCWA's Mandatory Training Requirements Document. Removed specific operator positions and combined them all under the "certified operator" position.</p>



OPERATIONAL PLAN

Wasaga Beach Well Supply System

QEMS Proc.: OP-11
Rev Date: 2024-11-08
Rev No: 8
Pages: 1 of 3

PERSONNEL COVERAGE

Reviewed by: Process & Compliance Technician

Approved by: Senior Operations Manager

1. Purpose

To describe the procedure for ensuring that sufficient and competent personnel are available for duties that directly affect drinking water quality at the Wasaga Beach Well Supply System.

2. Definitions

Competency – an integrated set of requisite skills and knowledge that enables an individual to effectively perform the activities of a given occupation *

Essential Services – services that are necessary to enable the employer to prevent,

- (a) danger to life, health or safety,
- (b) the destruction or serious deterioration of machinery, equipment or premises,
- (c) serious environmental damage, or
- (d) disruption of the administration of the courts or of legislative drafting.

(*Crown Employees Collective Bargaining Act, 1993*)

3. Procedure

3.1 Operations Management ensures that personnel meeting the competencies identified in OP-10 Competencies are available for duties that directly affect drinking water quality.

3.2 The Wasaga Beach Well Supply System is staffed by OCWA personnel as follows:

7:30 a.m. to 4:00 p.m. Monday to Friday

3.3 Operations personnel are assigned to act as and fulfill the duties of Overall Responsible Operator (ORO) and Operator-in-Charge (OIC) in accordance with SDWA O. Reg. 128/04.

The Senior Operations Manager designates an overall responsible operator (ORO) for Water Distribution and Supply in the Georgian Highlands Region – Georgian Bay Hub. When the ORO is unavailable, the Back-Up ORO is designated as the ORO and is recorded as such in the facility logbook. Refer to the current ORO posting at the facilities.

The designated OIC for each shift is recorded in the facility logbook.

3.4 The Senior Operations Manager or designate assigns an on-call Operator based on the on-call schedule for the time that the facility is un-staffed (i.e. evenings, weekends, and Statutory Holidays) to be available for return to work 24/7. The on-call shift change

* Based on the 2005 National Occupational Guidelines for Canadian Water and Wastewater Operators and International Board of Standards for Training, Performance and Instruction



OPERATIONAL PLAN
Wasaga Beach Well Supply System

QEMS Proc.: OP-11
Rev Date: 2024-11-08
Rev No: 8
Pages: 2 of 3

PERSONNEL COVERAGE

Reviewed by: Process & Compliance Technician

Approved by: Senior Operations Manager

is generally at the end of the business day on the Thursday of each week. The on-call schedule is developed by the Operators that are on-call for the system and given to the Senior Operations Manager or designate for approval.

- 3.5 The on-call Operator does not conduct a physical inspection of the facility during the weekends. However, during long (e.g. three-day) weekends due to Statutory Holidays, the on-call Operator does a physical inspection of the facility, typically on the Sunday. Details of the inspection are recorded in the facility logbook and daily round sheets.
- 3.6 The auto dialer is programmed to contact a contracted call-centre operator whenever there is an alarm condition. The call-centre operator contacts the on-call Operator through a designated text page. The on-call Operator contacts the call-centre to obtain the details of the alarm to determine the appropriate response. If the nature of the alarm requires additional staff, the on-call Operator can request assistance from any of the other Certified Operators within the system. The on-call Operator records details of the call-in in the facility logbook and in the Call-In Report within WMS.
- 3.7 Each manager (e.g. Operations Management/SPC Manager) is responsible for approving vacation time for their staff in a manner which ensures sufficient personnel are available for the performance of normal operating duties.
- 3.8 OCWA's operations personnel are represented by the Ontario Public Service Employees Union (OPSEU). In the event of a labour disruption, Operations Management, together with the union, identifies operations personnel to provide "essential services" required to operate the facility so that the quality of drinking water is not compromised in any way.
- 3.9 A contingency plan for Critical Shortage of Staff is included in the Facility Emergency Plan. This plan provides direction in the event that there is a severe shortage of operations personnel due to sickness (e.g., pandemic flu) or other unusual situations.

4. Related Documents

- OP-10 Competencies
- Facility Logbook
- Daily Round Sheets
- On-Call Schedule
- Call-In Reports
- Shift/Vacation Schedule
- Critical Shortage of Staff Contingency Plan (Facility Emergency Plan)



OPERATIONAL PLAN
Wasaga Beach Well Supply System

QEMS Proc.: OP-11
Rev Date: 2024-11-08
Rev No: 8
Pages: 3 of 3

PERSONNEL COVERAGE

Reviewed by: Process & Compliance Technician

Approved by: Senior Operations Manager

5. Revision History

Date	Revision #	Reason for Revision
2008-10-24	0	Procedure issued.
2010-08-27	1	CGSB Audit CAR #552 – Rev to Section 5.6 and addition of 5.9 and 5.10.
2011-10-06	2	Section 5.9 revised as per corporate revisions and section 5.10 removed.
2012-04-26	3	Position Title Change: Operations Manager now Senior Operations Manager and Cluster Manager now Operations Manager.
2014-11-10	4	Removed specific names of OCWA review and approval personnel.
2015-02-06	5	Section 5.6 revised to remove on-call pager and replace with text-page.
2018-05-25	6	Procedure issued following new template from Corporate Compliance. QP-03 procedure renamed OP-11. Removed Responsibilities and Scope sections. Other minor edits in wording.
2019-03-12	7	Reformatted procedure.
2024-11-08	8	Updated section 3.3 to identify that the Senior Operations Manager is represented by the Georgian Bay Hub (removed reference to North Simcoe Hub). General formatting changes. Removed watermark.



OPERATIONAL PLAN

Wasaga Beach Well Supply System

QEMS Proc.: OP-12
Rev Date: 2024-11-08
Rev No: 8
Pages: 1 of 4

COMMUNICATIONS

Reviewed by: Process & Compliance Technician

Approved by: Senior Operations Manager

1. Purpose

To describe the procedure for facility level internal and external QEMS-related communications between Top Management (or designate) and:

- OCWA staff;
- the Owner;
- essential suppliers and service providers (as identified in OP-13); and
- the public.

2. Definitions

Operations Management – refers to the General Manager, Senior Operations Manager and/or Operations Manager that directly oversees a facility's operations

Operations Personnel – employees of the drinking water system who perform various activities related to the compliance, operations and maintenance of the drinking water system that may directly affect drinking water quality.

3. Procedure

3.1 Operations Management and the QEMS Representative are responsible for identifying and coordinating any site-specific communications in relation to the status/ development of the facility's QEMS.

3.2 Internal and external communication responsibilities and reporting requirements for emergency situations are set out under OCWA's Emergency Management Program (i.e., Facility Emergency Plan and OCWA's Corporate Emergency Response Plan). Refer to OP-18 Emergency Management for more information.

3.3 Communication with OCWA staff:

3.3.1 Within the first year of hire, all staff are required to complete the Environmental Compliance 101 (EC101) course. The objective of the EC 101 course is to ensure that Staff are aware of applicable legislative and regulatory requirements and of OCWA's QEMS and to reinforce their roles and responsibilities under OCWA's QEMS.

3.3.2 Operations Management are responsible for ensuring operations personnel receive site-specific training on the Operational Plan, the organizational structure for the facility including the roles and responsibilities and authorities (outlined in OP-09 Organizational Structure, Roles, Responsibilities and Authorities), QEMS Procedures and other related operating instructions and procedures as part of the orientation process and on an on-going basis as required.



OPERATIONAL PLAN

Wasaga Beach Well Supply System

QEMS Proc.: OP-12
Rev Date: 2024-11-08
Rev No: 8
Pages: 2 of 4

COMMUNICATIONS

Reviewed by: Process & Compliance Technician | Approved by: Senior Operations Manager

3.3.3 The SPC Manager is responsible for ensuring training is provided for the Regional Hub (in consultation with Operations Management as required) on applicable legislative and regulatory requirements and the QEMS.

3.3.4 The QEMS Representative assists Operations Management and/or the SPC Manager in the coordination/delivery of training as required.

3.3.5 Revisions to the QEMS and associated documentation are communicated as per OP-05 Document and Records Control.

3.3.6 The QEMS Policy is available to all OCWA personnel through OCWA's Sharepoint Site and as outlined in 3.6.2 of this procedure.

3.3.7 Operations personnel are responsible for identifying potential hazards at the facility that could affect the environmental and/or public health, and communicating these to Operations Management. They may also recommend changes be made to improve the facility's QEMS by making a request to the QEMS Representative (as per OP-05).

3.3.8 The QEMS Representative is responsible for ensuring that the Operations Management and the Safety, Process and Compliance Manager are informed regarding the compliance/quality status of the facility and QEMS implementation and any need for improved processes/procedures at the facility level.

3.3.9 The SPC Manager reports to the Regional Hub Manager on the compliance status, the QEMS performance and effectiveness, any need for improvement and on issues that may have Agency-wide significance. Operations Management reports to the Regional Hub Manager on facility operational performance.

3.4 Communication with the Owner:

3.4.1 The Regional Hub Manager, Operations Management or designate ensures that the Owner is provided with QEMS updates and that they are kept informed of the status of the facility's operational and compliance performance during regularly scheduled meetings and/or through electronic and/or verbal communications. The QEMS Representative assists in the coordination of these meetings and with communicating the updates as directed.

3.4.2 The continuing suitability, adequacy and effectiveness of OCWA's QEMS are communicated to the Owner as part of the Management Review process (refer to OP-20 Management Review).

3.5 Communications with Essential Suppliers and Service Providers:

3.5.1 Communication requirements to ensure essential suppliers and service providers understand the relevant OCWA QEMS policies, procedures and expectations are described in OP-13 Essential Supplies and Services.



OPERATIONAL PLAN

Wasaga Beach Well Supply System

QEMS Proc.: OP-12
Rev Date: 2024-11-08
Rev No: 8
Pages: 3 of 4

COMMUNICATIONS

Reviewed by: Process & Compliance Technician | Approved by: Senior Operations Manager

3.6 Communication with the Public:

- 3.6.1 Media enquiries must be directed to the facility's designated media spokesperson as identified in the Facility Emergency Plan. The media spokesperson coordinates with local and corporate personnel (as appropriate) and the Owner in responding to media enquiries.
- 3.6.2 OCWA's QEMS and QEMS Policy are communicated to the public through OCWA's public website (www.ocwa.com). The QEMS Policy is also posted at the Wasaga Beach WPCP.
- 3.6.3 Facility tours of interested parties must be approved in advance by the Operations Management. Refer to Plant Tour Records.
- 3.6.4 All OCWA received complaints, whether received from the consumer, the community or other interested parties, are documented in OCWA's WMS. As appropriate, the Operations Management ensures that the Owner is informed of the complaint and/or an action is developed to address the issue in a timely manner. Community complaints received by the Corporation of the Town of Wasaga Beach are either addressed by Town staff or directed to OCWA as needed. The QEMS Representatives (for both the Town of Wasaga Beach and OCWA) ensure that consumer complaints/feedback is included for discussion annually at the Joint Management Review.

4. Related Documents

OP-05 Document and Records Control
OP-09 Organizational Structure, Roles, Responsibilities and Authorities
OP-13 Essential Supplies and Services
OP-18 Emergency Management
OP-20 Management Review
Facility Emergency Plan
Corporate Emergency Response Plan
Work Management System (WMS)
Plant Tour Records

5. Revision History

Date	Revision #	Reason for Revision
2008-10-22	0	Procedure issued.
2011-10-06	1	Changed Client Service Representative to new position title of Account Manager; revised step 5.2 to better describe how relevant aspects of the QEMS are communicated to OCWA personnel. (CGSB non-conformance).



OPERATIONAL PLAN
Wasaga Beach Well Supply System

QEMS Proc.: OP-12
Rev Date: 2024-11-08
Rev No: 8
Pages: 4 of 4

COMMUNICATIONS

Reviewed by: Process & Compliance Technician | Approved by: Senior Operations Manager

Date	Revision #	Reason for Revision
2012-04-26	2	Position Title Change: Operations Manager now Senior Operations Manager and Cluster Manager now Operations Manager and Account Manager now Account Service Representative.
2013-04-16	3	Revision to step 5.6 to correctly identify where the QEMS Policy is posted as per CAR #1 found during Internal Audit of 28-Mar-13.
2018-06-07	4	Procedure issued following new template from Corporate Compliance. QP-04 procedure renamed OP-12. Removed Responsibilities and Scope sections. Added definitions for Operations Management and Operations Personnel. Reordered and created separate sections to clarify communications to each of the 4 parties. Clarified suppliers were those listed as essential as per Element 13 (as per DWQMS v. 2.0) and replaced references to Senior Operations Manager with 'Operations Management'. Updated training sections for OCWA personnel (s. 3.3.1 to s. 3.3.4) to reference new Environmental Compliance 101 course completed within first year of hire and to outline how training is coordinated between SPC Manager/Operations Management, and QEMS Representative. SPC Manager listed as the responsible party in 3.3.3 instead of QEMS Representative. Included sections on R&Rs for performance reporting within OCWA (s. 3.3.7 to s. 3.3.9) and to Client (3.4.1). Replaced identification of media spokesperson (s. 3.6.1) with 'as identified in Facility Emergency Plan'. Added reference to site-specific records/documents used for recording tours (s. 3.6.3). Other minor edits.
2019-03-12	5	Updated to include clarification on the communication protocol with essential supplies and services contractors; specifically that the QEMS Representative/PCT provides the QEMS letter instead of Top Management as per External Audit (2019-02-08).
2021-06-09	6	Removed references to OPEX Database; replaced community complaint entries to utilize WMS
2024-02-07	7	Removed reference to OCWA's intranet in 3.3.6 and replaced with OCWA's Sharepoint Site.
2024-11-08	8	Procedure revised to reference updated title of Corporate Emergency Response Plan, removed watermark. Updated section on Communication with the Public, specifically 3.6.4 on how community complaints are handled when received. Removed reference of OPEX in related documents- OCWA community complaints received are recorded in WMS.



OPERATIONAL PLAN
Wasaga Beach Well Supply System

QEMS Proc.: OP-13
Rev Date: 2024-08-29
Rev No: 6
Pages: 1 of 3

ESSENTIAL SUPPLIES AND SERVICES

Reviewed by: Process & Compliance Technician

Approved by: Senior Operations Manager

1. Purpose

To describe OCWA's procedures for procurement and for ensuring the quality of essential supplies and services.

2. Definitions

Essential Supplies and Services – supplies and services deemed to be critical to the delivery of safe drinking water

3. Procedure

3.1 Essential supplies and services for the Wasaga Beach Well Supply System are contained in the Facility Emergency Plan, Essential Supplies and Services List. The list is reviewed and updated at least once every calendar year by the QEMS Representative.

3.2 Purchasing is conducted in accordance with OCWA's Corporate Procurement and Administration policies, procedures and guidelines, which are adopted from those of the Ontario Public Service.

Purchases of capital equipment are subject to formal approval by the facility's owner.

3.3 As part of the corporate procurement process, potential suppliers/service providers are informed of relevant aspects of OCWA's QEMS through the tendering process and through specific terms and conditions set out in our agreements and purchase orders. Essential suppliers and service providers (including those contracted locally) are sent a letter that provides an overview of the relevant aspects of the QEMS.

3.4 Contractors are selected based on their qualifications and ability to meet the facility's needs without compromising operational performance and compliance with applicable legislation and regulations.

Contracted personnel including suppliers may be requested or required to participate in additional relevant training/orientation activities to ensure conformance with facility procedures and to become familiar with OCWA workplaces.

If necessary, appropriate control measures are implemented while contracted work is being carried out and communicated to all relevant parties to minimize the risk to the integrity of the drinking water system and the environment.

3.5 All third-party drinking water testing services are provided by accredited and licensed laboratories. The Ministry has agreement with The Canadian Association for Laboratory Accreditation (CALA) for accreditation of laboratories testing drinking water. The QEMS Representative is responsible for notifying the Ministry of any change to the drinking water testing services being utilized.



OPERATIONAL PLAN
Wasaga Beach Well Supply System

QEMS Proc.: OP-13
Rev Date: 2024-08-29
Rev No: 6
Pages: 2 of 3

ESSENTIAL SUPPLIES AND SERVICES

Reviewed by: Process & Compliance Technician | Approved by: Senior Operations Manager

- 3.6 Internal verification and calibration activities (e.g. chlorine analyzer, turbidimeter, etc.) are conducted by operations personnel in accordance with equipment manuals and/or procedures (refer to OP-17 Measurement Recording Equipment Calibration and Maintenance).
- 3.7 External calibration activities (e.g. flow meters) are conducted by qualified third-party providers. Qualifications of the service provider are verified during the procurement process. The service provider is responsible for providing a record/certificate of all calibrations conducted.
- 3.8 Chemicals purchased for use in the drinking water treatment process must meet AWWA Standards and be ANSI/NSF certified as per the Municipal Drinking Water Licence (MDWL).
- 3.9 The facility orders and receives ongoing deliveries of chemicals to satisfy current short-term needs based on processing volumes and storage capacities. Incoming chemical orders are verified by reviewing the manifest or invoice in order to confirm that the product received is the product ordered.
- 3.10 Process components/equipment provided by the supplier must meet applicable regulatory requirements and industry standards for use in drinking water systems prior to their installation.

4. Related Documents

Essential Supplies and Services List
OP-17 Measurement Recording Equipment Calibration and Maintenance
ANSI/NSF Documentation
AWWA Standards
MDWL
Calibration Certificates/Records

5. Revision History

Date	Revision #	Reason for Revision
2008-10-27	0	Procedure issued.
2011-10-06	1	Added Section 5.3 to further describe how relevant aspects of the QEMS are communicated to suppliers; other sections renumbered accordingly.
2012-04-26	2	Position Title Change: Operations Manager now Senior Operations Manager.
2014-03-17	3	Revised as per Internal QEMS Audit of March 28, 2013.



OPERATIONAL PLAN
Wasaga Beach Well Supply System

QEMS Proc.: OP-13
Rev Date: 2024-08-29
Rev No: 6
Pages: 3 of 3

ESSENTIAL SUPPLIES AND SERVICES

Reviewed by: Process & Compliance Technician

Approved by: Senior Operations Manager

Date	Revision #	Reason for Revision
2018-06-07	4	Procedure updated following new template from Corporate Compliance. QP-05 procedure renamed OP-13. Removed Responsibilities and Scope sections. Changes to wording to provide clarification on ensuring quality of essential supplies and services (s. 3.5, 3.6, 3.7 and 3.9).
2020-01-02	5	Any reference to the MOECC was updated to MECP, as identified in the 2019 Internal Audit process.
2024-08-29	6	Any reference to the MECP was updated to the Ministry. Removed Watermark



OPERATIONAL PLAN
Wasaga Beach Well Supply System

QEMS Proc.: OP-14
Rev Date: 2024-08-21
Rev No: 7
Pages: 1 of 2

REVIEW AND PROVISION OF INFRASTRUCTURE

Reviewed by: Process & Compliance Technician

Approved by: Senior Operations Manager

1. Purpose

To describe OCWA's procedure for reviewing the adequacy of infrastructure necessary to operate and maintain the Wasaga Beach Well Supply System.

2. Definitions

Infrastructure – the set of interconnected structural elements that provide the framework for supporting the operation of the drinking water system, including buildings, workspace, process equipment, hardware, software and supporting services, such as transport or communication

3. Procedure

3.1 At least once every calendar year, Operations Management in conjunction with the applicable operations personnel conduct a review of the drinking water system's infrastructure to assess its adequacy for the operation and maintenance of the system. Operations personnel assist with identifying the need for infrastructure repairs, replacements or alterations and with prioritizing each identified item. Documents and records that are reviewed may include:

- Maintenance records
- Call-in reports
- Adverse Water Quality Incidents (AWQIs) or other incidents
- Health & Safety Inspections
- Ministry Inspection Reports
- Facility Logbooks
- Operational Staff Suggestions
- DWQMS Management Review

3.2 The outcomes of the risk assessment documented as per OP-08 are considered as part of this review.

3.3 The output of the review is a multi-year rolling Capital Works Spreadsheet to assist the Owner and OCWA with planning infrastructure needs for the short and long-term. This report is submitted, at least once every calendar year by Operations Management, to the Owner for review and approval. Together with the Owner, Operations Management determines and documents timelines and responsibilities for implementation of priority items.

3.4 The final approved Capital Works Spreadsheet forms the long term forecast for any major infrastructure maintenance, rehabilitation and renewal activities as per OP-15.

3.5 Operations Management ensures that results of this review are considered during the Management Review process (OP-20).



OPERATIONAL PLAN
Wasaga Beach Well Supply System

QEMS Proc.: OP-14
Rev Date: 2024-08-21
Rev No: 7
Pages: 2 of 2

REVIEW AND PROVISION OF INFRASTRUCTURE

Reviewed by: Process & Compliance Technician

Approved by: Senior Operations Manager

4. Related Documents

Capital Works Spreadsheet & Acknowledgement/Approval from the Owner
OP-08 Risk Assessment Outcomes
OP-15 Infrastructure Maintenance, Rehabilitation and Renewal
OP-20 Management Review
Management Review Minutes

5. Revision History

Date	Revision #	Reason for Revision
2008-10-24	0	Procedure issued.
2012-04-26	1	Position Title Change: Operations Manager now Senior Operations Manager
2014-11-14	2	Removed specific names of OCWA review and approval personnel
2018-06-19	3	Procedure updated following new template from Corporate Compliance. QP-06 procedure renamed OP-14. Removed Responsibilities and Scope sections. Replaced 'once every 12 months' with 'once every calendar year' (s. 3.1) to reflect wording in DWQMS v. 2.0. Added s. 3.2 to consider the outcomes of the risk assessment under Element 8 during the review to reflect wording in DWQMS v. 2.0. Changes to wording to provide clarification on who is required to attend the review and what documents and records may be considered during the review (s. 3.1). Linked the procedure with OP-15 in terms of documenting a long-term forecast (s. 3.3 and s. 3.4).
2022-01-10	4	Changed wording from 6 year rolling Capital Works Spreadsheet under 3.3 to "multi-year" rolling Capital Works Spreadsheet
2022-03-25	5	Any reference to the MOECC was updated to MECP, as identified in the 2022 External Audit process.
2023-01-23	6	Minor updates and editing, placed 4 header (Related Documents) back in line with text body as recommended by 2022 Internal Audit.
2024 -08-21	7	Removed watermark. Replaced MECP with Ministry



OPERATIONAL PLAN

Wasaga Beach Well Supply System

QEMS Proc.: OP-15
Rev Date: 2024-08-21
Rev No: 4
Pages: 1 of 3

INFRASTRUCTURE MAINTENANCE, REHABILITATION AND RENEWAL

Reviewed by: Process & Compliance Technician

Approved by: Senior Operations Manager

1. Purpose

To describe OCWA's infrastructure maintenance, rehabilitation and renewal program for the Wasaga Beach Well Supply System.

2. Definitions

Infrastructure – the set of interconnected structural elements that provide the framework for supporting the operation of the drinking water system, including: buildings, workspace, process equipment, hardware, software and supporting services, such as transport or communication

Rehabilitation – the process of repairing or refurbishing an infrastructure element.

Renewal – the process of replacing the infrastructure elements with new elements.

3. Procedure

3.1 OCWA, under contract with the Owner, maintains a computerized Work Management System (WMS) to manage maintenance, rehabilitation and renewal of infrastructure for which it is operationally responsible. The major components of the WMS consist of planned maintenance, unplanned maintenance, rehabilitation, renewal and program monitoring and reporting.

3.1.1 Planned Maintenance

Routine planned maintenance activities include: pump inspections, analyzer calibrations, flow meter calibrations, valve inspections, reservoir inspections, backup diesel operation and testing, weekly inspections of the facility, etc.

Planned maintenance activities are scheduled in the WMS that allows the user to:

- Enter detailed asset information;
- Generate and process work orders;
- Access maintenance and inspection procedures;
- Plan preventive maintenance and inspection work;
- Plan, schedule and document all asset related tasks and activities; and
- Access maintenance records and asset histories.

Planned maintenance activities are communicated to the person responsible for completing the task through the issuance of WMS work orders. Work orders are automatically generated on a daily, weekly, monthly, quarterly and annual schedule as determined based on manufacturer's recommendations and site specific operational and maintenance needs and are assigned directly to the appropriate operations personnel. This schedule is set up by the WMS Primary, Operations Management, Operations Supervisor, O&M Team Lead and/or applicable Operations personnel. Work orders are completed and electronically



OPERATIONAL PLAN
Wasaga Beach Well Supply System

QEMS Proc.: OP-15
Rev Date: 2024-08-21
Rev No: 4
Pages: 2 of 3

INFRASTRUCTURE MAINTENANCE, REHABILITATION AND RENEWAL

Reviewed by: Process & Compliance Technician

Approved by: Senior Operations Manager

entered into WMS by the person responsible for completing the task. Records of these activities are maintained as per OP-05 Document and Records Control.

The WMS Primary, Operations Management, Operations Supervisor, Asset Management Specialist and/or O&M Team Lead maintain the inventory of equipment in WMS and ensure that appropriate maintenance plans are in place. Maintenance plans are developed according to the manufacturer's instructions, regulatory requirements, industry standards, and/or client service requirements. Equipment Operation and Maintenance (O&M) manuals are accessible to operations personnel at the locations specified in OP-05 Document and Records Control.

3.1.2 Unplanned Maintenance

Unplanned maintenance is conducted as required. All unplanned maintenance activities are authorized by the Operations Management. Unplanned maintenance activities are recorded on corrective work orders and are entered into WMS by the person responsible for completing the unplanned maintenance activity.

3.1.3 Rehabilitation and Renewal

Rehabilitation and renewal activities including capital upgrades (major infrastructure maintenance) are determined at least once every calendar year in consultation with Operations Management and the Owner. A list of required replacement or desired new equipment is compiled and prioritized by Operations Management in conjunction with operations personnel and is presented to the Owner for review and comment. All major expenditures require the approval of the Owner. In addition to the short-term facility needs (i.e. current year), the Capital Works Spreadsheet also provides a long-term (i.e. multi-year rolling) list of major maintenance recommendations (refer to OP-14 Review and Provision of Infrastructure).

3.1.4 Program Monitoring and Reporting

Maintenance needs for the facility are determined through review of manufacturer's instructions, regulatory requirements, industry standards, and/or client service requirements and are communicated by means of work orders. Additionally, Operations Management, Operations Supervisor and Operations personnel (e.g. Senior Operator, O&M Team Lead, etc.) conduct a review of the drinking water system's infrastructure to assess its adequacy for the operation and maintenance of the system (refer to OP-14 Review and Provision of Infrastructure).

To assist in monitoring the effectiveness of the program, the WMS is set up so Senior Operations Managers can track the Work Order Status by using the start centre for review of work order completion rate. This report tracks corrective, preventative, weekly, capital and operational work orders in terms of incomplete



OPERATIONAL PLAN

Wasaga Beach Well Supply System

QEMS Proc.: OP-15
Rev Date: 2024-08-21
Rev No: 4
Pages: 3 of 3

INFRASTRUCTURE MAINTENANCE, REHABILITATION AND RENEWAL

Reviewed by: Process & Compliance Technician

Approved by: Senior Operations Manager

work orders for all facilities in the Georgian Bay Hub, including the Wasaga Beach Well Supply System.

3.2 OCWA's infrastructure maintenance, rehabilitation and renewal program is initially communicated to the Owner through the operating agreement. OCWA's program is communicated to the Owner at a minimum of at least once every calendar year through submission of the Capital Works Spreadsheet and through the results of the Management Review.

4. Related Documents

Minutes of Management Review
Capital Works Spreadsheet & Acknowledgement/Approval from the Owner
Equipment Operations & Maintenance Manuals
OP-05 Document and Records Control
OP-14 Review and Provision of Infrastructure

5. Revision History

Date	Revision #	Reason for Revision
2018-06-19	0	Procedure issued – Information within OP-15 was originally set out in the Main Body of OCWA's Operational Plan (last revision 7 dated 2016-06-22). New Purpose, Definitions, Procedure, Related Documents and separate Revision History sections. Added the requirement to ensure the long term forecast is reviewed at once every calendar year and to document a long term forecast (s. 3.1.3) to reflect in DWQMS v. 2.0. Minor wording updates to reflect OCWA's current WMS.
2019-03-12	1	Clarified which position creates the Hub Work Order Report (i.e. SPC Manager) referenced in section 3.1.4 and the contents of the report.
2022-03-25	2	Updated section 3.1.4 Program Monitoring and Reporting, to reflect how Hub Work Orders are monitored in the Work Management System by the Senior Operations Manager who can track the Work Order Status by using the start centre for review of w/o completion rate.
2024-02-07	3	Updated 6-year report to multi-year rolling report.
2024-08-21	4	Procedure updated. Added in mentions to the Operations Supervisor and Asset Management Specialist roles. Removed watermark



OPERATIONAL PLAN

Wasaga Beach Well Supply System

QEMS Proc.: OP-16
Rev Date: 2024-08-21
Rev No: 4
Pages: 1 of 3

SAMPLING, TESTING AND MONITORING

Reviewed by: Process & Compliance Technician

Approved by: Senior Operations Manager

1. Purpose

To describe the procedure for sampling, testing and monitoring for process control and finished drinking water quality.

2. Definitions

Challenging Conditions – any existing characteristic of the water source or event-driven fluctuations that impact the operational process as identified and listed under OP-06 Drinking Water System

3. Procedure

3.1 All sampling, monitoring and testing is conducted at a minimum in accordance with SDWA O. Reg. 170/03, the facility's Municipal Drinking Water License (MDWL) as well as sampling/testing and monitoring requirements listed within the facility's Permit to Take Water (e.g. recording monitoring well levels).

3.2 Sampling requirements for the facility are defined in the facility's sampling schedule, plan, and/or calendar which are available to Operations personnel at the location(s) noted in OP-05 Document and Records Control. The sampling schedule is maintained by the PCT and is updated as required.

3.3 Samples that are required to be tested by an accredited and licensed laboratory, are collected, handled and submitted according to the directions provided by the licensed laboratory(ies) that conducts the analysis. The laboratories used for this facility are listed in the Essential Supplies and Services List (within the Facility Emergency Plan (FEP)).

Electronic reports received from the laboratory are maintained as per OP-05 Document and Records Control. Analytical results from laboratory reports are uploaded into OCWA's Process Data Management system (PDM).

3.4 Continuous monitoring equipment is used to sample and test for treated water turbidity, treated water free chlorine residual and distribution free chlorine residual. Test results from continuous monitoring equipment are captured by the SCADA system and are reviewed by a certified operator in accordance with the requirements of SDWA O. Reg. 170/03.

The SCADA system also collects and records information on the following parameters related to process control and finished drinking water quality:

- Raw and Treated Water Flow and Rates
- Reservoir Levels
- Tower Levels
- System Pressures (at both facilities)



OPERATIONAL PLAN

Wasaga Beach Well Supply System

QEMS Proc.: OP-16
Rev Date: 2024-08-21
Rev No: 4
Pages: 2 of 3

SAMPLING, TESTING AND MONITORING

Reviewed by: Process & Compliance Technician | Approved by: Senior Operations Manager

The SOP titled “Operating Procedures for Routine Operation of the Works” and the SOP for “Daily SCADA Review” provides additional information on the SCADA system. These Standard Operating Procedures are included in the Operations Manuals.

- 3.5 Adverse water quality incidents are responded to and reported as per SOP for “Adverse Water Quality,” which is located within the FEP.
- 3.6 In-house process control activities conducted on a regular basis by certified operator(s) on duty are as follows:

Operational Parameter	Location	Minimum Frequency
Turbidity	Powerline Raw water tap- each well	Grab monthly
Turbidity	Jenetta Raw water tap- each well	Grab monthly
Turbidity	Powerline Treated water tap	Monday to Friday - Grab
Turbidity	Jenetta Treated water tap	Monday to Friday - Grab
Free Chlorine	Powerline Treated water tap	Monday to Friday - Grab
Free Chlorine	Jenetta Treated water tap	Monday to Friday - Grab
Free Chlorine	Distribution - 30 Woodland Drive Distribution – Sunnidale Booster Station	Online Continuous Analyzer
Sodium Hypochlorite Usage	Powerline - SCADA	Monday to Friday Readings
Sodium Hypochlorite Usage	Jenetta - Chemical room	Monday to Friday Readings
Sodium Silicate Usage	Powerline - Chemical room	Monday to Friday Readings
Sodium Silicate Usage	Jenetta - Chemical room	Monday to Friday Readings

In-house samples are analyzed following approved laboratory procedures. The sampling results are recorded on the corresponding monthly data sheet. The results are entered into PDM. Any required operational process adjustments are recorded in the facility log book.

- 3.7 There are no additional sampling, testing, and monitoring activities related to the system’s most challenging conditions as these conditions are not applicable.
- 3.8 There are no relevant upstream sampling, testing, and monitoring activities that take place for this facility.
- 3.9 Sampling, testing and monitoring results are readily accessible to the Owner, as the Town of Wasaga Beach is included on the electronic sample result submissions from the external laboratory.

At a minimum, Owners are provided with an annual summary of sampling, testing and monitoring results through the SDWA O. Reg. 170/03 Section 11 Annual Report, the Schedule 22 Municipal Summary Report and through the Management Review process outlined in OP-20 Management Review.

In addition, updates regarding sampling, testing and monitoring activities are provided as per the operating agreement and during regular client meetings.



OPERATIONAL PLAN

Wasaga Beach Well Supply System

QEMS Proc.: OP-16
Rev Date: 2024-08-21
Rev No: 4
Pages: 3 of 3

SAMPLING, TESTING AND MONITORING

Reviewed by: Process & Compliance Technician | Approved by: Senior Operations Manager

4. Related Documents

Facility Logbook
OP-05 Document and Records Control
OP-06 Drinking Water System
OP-20 Management Review
Laboratory Analysis Reports
Laboratory Chain of Custody Forms
Annual Report (O. Reg. 170 Section 11)
Municipal Summary Report (O. Reg. 170 Schedule 22)
Process Data Management System (PDM) records
Emergency Contact List and Essential Supplies & Services List (Contacts section of FEP)
Facility Emergency Plan (FEP) Binder
SOP – Adverse Water Quality (FEP Binder)
Monthly Data Sheet
Sampling Schedule/Plan/Calendar
SCADA Records

5. Revision History

Date	Revision #	Reason for Revision
2008-10-31	0	Procedure issued.
2012-04-26	1	Position Title Change: Operations Manager now Senior Operations Manager and Cluster Manager now Operations Manager.
2014-11-10	2	Removed specific names of OCWA review and approval personnel.
2018-06-19	3	Procedure updated following new template from Corporate Compliance. QP-07 procedure renamed OP-16. Removed Responsibilities and Scope sections. Updated s. 3.1 to reference Municipal Drinking Water License and s. 3.2 to reference sampling calendar/plan and removed sampling table. Expanded information related to accredited and licensed laboratories (s. 3.3). Reordered some sections and other minor edits.
2024-08-21	4	Procedure updated to include that the Town of Wasaga Beach is included on sampling results from the external laboratory. Removed watermark, other minor wording edits



OPERATIONAL PLAN
Wasaga Beach Well Supply System

QEMS Proc.: OP-17
Rev Date: 2024-08-21
Rev No: 4
Pages: 1 of 2

MEASUREMENT AND RECORDING EQUIPMENT CALIBRATION AND MAINTENANCE

Reviewed by: Process & Compliance Technician | Approved by: Senior Operations Manager

1. Purpose

To describe the procedure for the calibration and/or verification and maintenance of measurement and recording equipment at the Wasaga Beach Well Supply System.

2. Definitions

None

3. Procedure

- 3.1 All measurement and recording equipment calibration and maintenance activities must be performed by appropriately trained and qualified personnel or by a qualified third-party calibration service provider (refer to OP-13 Essential Supplies and Services).
- 3.2 The Operator/Operations Manager/Operations Supervisor - establishes and maintains a list of measurement and recording devices and associated calibration and/or verification schedules using the automated Work Management System (WMS). When a new device is installed, it is added to the WMS system by the WMS Primary, Senior Operations Manager Operations Supervisor, O&M Team Lead or Asset Management Specialist. The new device is tagged with a unique identification number and the maintenance schedule is set up. Work orders are then automatically generated as per the schedule (refer to OP-15 Infrastructure Maintenance, Rehabilitation and Renewal).
- 3.3 Details regarding the results of the calibration and/or verification are recorded within each individual work order generated by the WMS.
- 3.4 Calibration and maintenance activities are carried out in accordance with procedures specified in the manufacturer's manual, instructions specified in WMS.
- 3.5 Standards, reagents and/or chemicals that may be utilized during calibration and/or verification and/or maintenance activities are verified before use to ensure they are not expired. Any expired standards, reagents and/or chemicals are appropriately disposed of and are replaced with new standards, reagents and/or chemicals as applicable. Additionally, a work order is issued on a monthly basis to ensure that standards, reagents and/or chemicals utilized during calibration and/or verification and/or maintenance within the system are verified.
- 3.6 Any measurement device which does not meet its specified performance requirements during calibration and/or verification must be removed from service (if practical) until repaired, replaced or successfully calibrated. The failure must be reported to the Operations Management, ORO, OIC on duty and/or PCT as soon as possible so that immediate measures can be taken to ensure that drinking water quality has not been compromised by the malfunctioning device. Any actions taken as a result of the failure are recorded in the facility logbook. The PCT or designate ensures that any notifications



OPERATIONAL PLAN
Wasaga Beach Well Supply System

QEMS Proc.: OP-17
Rev Date: 2024-08-21
Rev No: 4
Pages: 2 of 2

MEASUREMENT AND RECORDING EQUIPMENT CALIBRATION AND MAINTENANCE

Reviewed by: Process & Compliance Technician | Approved by: Senior Operations Manager

required by applicable legislation are completed and documented within the specified time period.

3.7 Calibration and maintenance records and maintenance/equipment manuals are maintained as per OP-05 Document and Records Control.

4. Related Documents

- Facility Logbook
- WMS Records
- Calibration/Maintenance Records
- Maintenance/Equipment Manuals
- OP-05 Document and Records Control
- OP-13 Essential Supplies and Services
- OP-15 Infrastructure Maintenance, Rehabilitation and Renewal

5. Revision History

Date	Revision #	Reason for Revision
2008-10-21	0	Procedure issued.
2012-04-26	1	Position Title Change: Operations Manager now Senior Operations Manager and Cluster Manager now Operations Manager.
2014-11-10	2	Removed specific names of OCWA review and approval personnel.
2018-06-19	3	Procedure updated following new template from Corporate Compliance. QP-08 procedure renamed OP-17. Removed Responsibilities and Scope sections. Added s. 3.3 to clarify how calibration and/or verification activities are documented. Added s. 3.5 to include how standards, reagents and/or chemicals are verified before use to ensure they are not expired. Other minor edits.
2024-08-21	4	Procedure 3.2 updated- Removed Safety, Process and Compliance Manager and replaced with Operator/Operations Manager/Operations Supervisor - establishes and maintains a list of measurement and recording devices, 3.6 Added on duty OIC to list of those to be notified, removed water mark



OPERATIONAL PLAN

Wasaga Beach Well Supply System

QEMS Proc.: OP-18
Rev Date: 2024-08-21
Rev No: 5
Pages: 1 of 4

EMERGENCY MANAGEMENT

Reviewed by: Process & Compliance Technician

Approved by: Senior Operations Manager

1. Purpose

To describe the procedure for maintaining a state of emergency preparedness at the facility level under OCWA's Emergency Management Program.

2. Definitions

Corporate Emergency Response Plan (CERP) – a corporate-level emergency preparedness plan for responding to and supporting serious (Level 3) operations emergencies

Facility Emergency Plan (FEP) – a facility-level emergency preparedness plan for responding to and recovering from operations emergencies

Operations Management – refers to the General Manager, Senior Operations Manager and/or Operations Manager that directly oversees a facility's operations

3. Procedure

3.1 The Facility Emergency Plan (FEP) is the corporate standard for emergency management at OCWA-operated facilities. The FEP supports the facility-level response to and recovery from Level 1, 2 and 3 events related to water and wastewater operations and directly links to the Corporate Emergency Response Plan (CERP) for management of Level 3 events that require corporate support. Operations Management is responsible for establishing a site-specific FEP that meets the corporate standard for this drinking water system.

3.2 OCWA recognizes three levels of events:

Level 1 is an event that can be handled entirely by plant staff and regular contractors. The event and the actions taken to resolve it (and to prevent a reoccurrence, if possible) are then included in regular reporting (both internally and externally). Examples may include response to an operational alarm, first aid incident, small on-site spill, or a process upset that can be easily brought under control.

Level 2 is an event that is more serious and requires immediate notification of others (regulator, owner). Examples may include minor basement flooding, injury to staff that requires medical attention, or a spill that causes or is likely to cause localized, off-site adverse effects. If the event reaches this level, the instructions indicate the need to contact the Regional Hub Manager.

Level 3 is an actual or potential situation that will likely require significant additional resources and/or threatens continued operations. It may require corporate-level support including activation of the OCWA Action Group and opening of an Emergency Operations Centre (EOC) as described in the CERP. Level 3 events usually involve



OPERATIONAL PLAN
Wasaga Beach Well Supply System

QEMS Proc.: OP-18
Rev Date: 2024-08-21
Rev No: 5
Pages: 2 of 4

EMERGENCY MANAGEMENT

Reviewed by: Process & Compliance Technician | Approved by: Senior Operations Manager

intervention from outside organizations (client, emergency responders, Ministry, media, etc.). Examples may include:

- Disruption of service/inability to meet demand;
- Critical injury including loss of life;
- Breach of security that is a threat to public health;
- Intense media attention;
- Community emergency affecting water supply/treatment;
- Declared pandemic; or
- Catastrophic failure that could impact public health or the environment or cause significant property damage.

3.3 Potential emergency situations or service interruptions identified for the Wasaga Beach Well Supply System include:

- Unsafe Water
- Spill Response
- Critical Injury
- Critical Shortage of Staff
- Loss of Service
- Security Breach

3.4 The processes for responding to and recovering from each potential emergency situation/service disruption are documented within a site-specific contingency plan (CP). The CPs and related Standard Operating Procedures (SOPs) are contained within the FEP.

3.5 OCWA's training requirements related to the FEP are as follows:

Training Topic	Training Provider	Type of Training	Frequency	Required For
Establishing and maintaining a FEP that meets the corporate standard	Safety, Process and Compliance Manager and/or Corporate Compliance (as required)	On-the-Job Practical	Upon hire and when changes are made to the corporate standard*	PCTs (or others identified by the Operations Management)
Contents of the site-specific FEP	Facility Level (coordinated by QEMS Representative)	On-the-Job Practical	Upon hire and when changes to the FEP are made*	All operations personnel with responsibilities for responding to an emergency

*Note: Changes to the corporate standard or site-specific FEP may only require the change to be communicated to Operations for implementation. Therefore, not all changes will require training.

3.6 At least one CP must be tested each calendar year and each CP must be reviewed at least once in a five-calendar year period. The reviews and tests are recorded on the FEP-01 Contingency Plan Review/Test Summary Form. This record includes the outcomes of the review/test, and identifies any opportunities for improvement and actions taken. A scheduled test of a CP may be regarded as a review of that particular CP as long as the outcomes are evaluated using the FEP-01 form. A CP-related



OPERATIONAL PLAN

Wasaga Beach Well Supply System

QEMS Proc.: OP-18
Rev Date: 2024-08-21
Rev No: 5
Pages: 3 of 4

EMERGENCY MANAGEMENT

Reviewed by: Process & Compliance Technician | Approved by: Senior Operations Manager

response to an actual event may also be considered a review or a test. A review of the incident including lessons learned should be recorded on FEP-01 following the resolution of the actual event, along with any opportunities for improvement/actions identified.

- 3.7 Revisions to the CPs, SOPs and other FEP documents are made (as necessary) following a review, test, actual event or other significant change (e.g., changes in regulatory requirements, corporate policy or operational processes and/or equipment, etc.). Results of the emergency response testing and any opportunities for improvement/actions identified are considered during the Management Review (OP-20).
- 3.8 Roles and responsibilities for emergency management at OCWA-operated facilities are set out in the FEP. Specific roles and responsibilities related to a particular emergency situation or service interruption (including those of the Owner where applicable) are set out in the relevant site-specific CP. A general description of the respective responsibilities of the Owner and the operating authority in the event an emergency occurs is included in the service agreement with the Owner (as required by the *Safe Drinking Water Act*).
- 3.9 Where they exist, any relevant sections of the Municipal Emergency Response Plan (MERP) are included or referenced in the appendices section of the FEP. Measures specified in the MERP are incorporated into CPs where appropriate.
- 3.10 An emergency contact list in conjunction with the essential supplies and services list is contained within the FEP and is reviewed (and updated as required) at least once per calendar year. An emergency communications protocol is contained within the FEP. Specific notification requirements during emergency situations or service interruptions are set out in the individual CPs and in the CERP.

4. Related Documents

- Facility Emergency Plan
- Corporate Emergency Response Plan
- FEP-01 Contingency Plan Review/Test Summary Form
- Municipal Emergency Response Plan (as applicable)
- Emergency Contact List/Essential Supplies & Services List (Contacts section of FEP)
- OP-20 Management Review

5. Revision History

Date	Revision #	Reason for Revision
2008-10-21	0	Procedure issued
2012-04-26	1	Position Title Change: Operations Manager now Senior Operations Manager and Cluster Manager now Operations Manager
2014-11-10	2	Removed specific names of OCWA review and approval personnel



OPERATIONAL PLAN
Wasaga Beach Well Supply System

QEMS Proc.: OP-18
Rev Date: 2024-08-21
Rev No: 5
Pages: 4 of 4

EMERGENCY MANAGEMENT

Reviewed by: Process & Compliance Technician | Approved by: Senior Operations Manager

Date	Revision #	Reason for Revision
2017-01-26	3	Section 5.2 (now 3.3 as per Rev 4) revised to match revised list of Corporate contingencies.
2018-06-19	4	Procedure updated following new template from Corporate Compliance. QP-09 procedure renamed OP-18. Removed Responsibilities and Scope sections and reordered some sections. Added definition 'Operations Management'. Throughout procedure replaced 'Senior Operations Manager' references with 'Operations Management'. Removed references to 'OCWA's Approach to Facility Emergency Planning' document throughout procedure and referenced FEP instead. Aligned wording for level 1, 2 & 3 events (s. 3.2) with wording in 'OCWA's Emergency Response Plan'. Updated training section to include role of SPC Manager (s. 3.5) and expanded testing/review section specifically to clarify how an actual test is documented (s. 3.6). Other minor edits.
2024-08-21	5	Procedure updated as follows: Ministry of Environment and Climate Change revised to Ministry, removed watermark. Modified references to Emergency Response Plan to indicate it is now referred to as Corporate Emergency Response Plan (CERP).

 Ontario Clean Water Agency	OPERATIONAL PLAN Wasaga Beach Well Supply System	QEMS Proc.: OP-19 Rev Date: 2024-11-08 Rev No: 5 Pages: 1 of 5
INTERNAL QEMS AUDITS		
Reviewed by: Process & Compliance Technician	Approved by: Senior Operations Manager	

1. Purpose

To describe the procedure for conducting internal audits at the facility level that evaluate the conformance of OCWA's Quality & Environmental Management System (QEMS) to the requirements of the Drinking Water Quality Management Standard (DWQMS).

This procedure applies to Internal QEMS Audits conducted at the Wasaga Beach Well Supply System for the purpose of meeting the DWQMS requirements for internal audits.

Note: this procedure does not apply to internal compliance audits conducted in accordance with OCWA's Internal Audit Program.

2. Definitions

Audit Team – one or more Internal Auditors conducting an audit

Internal Auditor – an individual selected to conduct an Internal QEMS Audit

Internal QEMS Audit – a systematic and documented internal verification process that involves objectively obtaining and evaluating documents and processes to determine whether a quality management system conforms to the requirements of the DWQMS

Lead Auditor – Internal Auditor responsible for leading an Audit Team

Non-conformance – non-fulfillment of a DWQMS requirement

Objective Evidence – verifiable information, records or statements of facts. Audit evidence is typically based on interviews, examination of documents, observations of activities and conditions, reviewing results of measurements and tests or other means. Information gathered through interviews should be verified by acquiring supporting information from independent sources.

Opportunity for Improvement (OFI) – an observation about the QEMS that may, in the opinion of the Internal Auditor, offer an opportunity to improve the effectiveness of the system or prevent future problems; implementation of an OFI is optional.

3. Procedure

3.1 Audit Objectives, Scope and Criteria

3.1.1 In general, the objectives of an internal QEMS audit are:

- To evaluate conformance of the implemented QEMS to the requirements of the DWQMS;
- To identify non-conformances with the documented QEMS; and
- To assess the effectiveness of the QEMS and assist in its continual improvement.



OPERATIONAL PLAN

Wasaga Beach Well Supply System

QEMS Proc.: OP-19
Rev Date: 2024-11-08
Rev No: 5
Pages: 2 of 5

INTERNAL QEMS AUDITS

Reviewed by: Process & Compliance Technician | Approved by: Senior Operations Manager

3.1.2 The scope of an internal QEMS audit includes activities and processes related to the QEMS as documented in the Operational Plan.

- 3.1.3 The criteria covered by an internal QEMS audit include:
- Drinking Water Quality Management Standard (DWQMS)
 - Current Operational Plan
 - QEMS-related documents and records

3.1.4 The audit scope and criteria may be customized as necessary to focus on a particular process/critical control point and/or any elements of the DWQMS which may warrant specific attention. The results of previous internal and external audits should also be considered.

3.2 Audit Frequency

- 3.2.1 Internal QEMS audits may be scheduled and conducted once every calendar year or may be separated into smaller audit sessions scheduled at various intervals throughout the calendar year. However, all elements of the DWQMS must be audited at least once every calendar year.
- 3.2.2 The QEMS Representative is responsible for maintaining the internal QEMS audit schedule. The audit schedule may be modified based on previous audit results.

3.3 Internal Auditor Qualifications

- 3.3.1 Internal QEMS audits shall only be conducted by persons approved by the QEMS Representative and having the following minimum qualifications:
- Internal auditor training or experience in conducting management system audits; and
 - Familiarity with the DWQMS requirements.
- 3.3.2 Internal Auditors that do not meet the qualifications in section 3.3.1 may form part of the Audit Team for training purposes, but cannot act as Lead Auditor.
- 3.3.3 Internal Auditors must remain objective and, where practical, be independent of the areas/activities being audited. It may not be possible for internal auditors to be fully independent of the activity being audited, but every effort should be made to remove bias and encourage objectivity. Auditors should maintain objectivity throughout the audit process to ensure that the audit findings and conclusions are based only on the audit evidence. Objectivity can be demonstrated by obtaining sufficient appropriate evidence to provide a reasonable basis for the audit findings.

 Ontario Clean Water Agency	OPERATIONAL PLAN Wasaga Beach Well Supply System	QEMS Proc.: OP-19 Rev Date: 2024-11-08 Rev No: 5 Pages: 3 of 5
INTERNAL QEMS AUDITS		
Reviewed by: Process & Compliance Technician	Approved by: Senior Operations Manager	

3.4 Audit Preparation

3.4.1 Together, the QEMS Representative and the Lead Auditor:

- Establish the audit objectives, scope and criteria;
- Confirm the audit logistics (locations, dates, expected time and duration of audit activities, any health and safety considerations, availability of key personnel, audit team assignments, etc.).

3.4.2 Each Internal Auditor is responsible for:

- Reviewing documentation to prepare for their audit assignments including:
 - the Operational Plan and related procedures;
 - results of previous internal and external QEMS audits;
 - the status and effectiveness of corrective and preventive actions implemented;
 - the results of the management review;
 - the status/consideration of OFIs identified in previous audits; and
 - other relevant documentation.
- Preparing work documents (e.g., checklists, forms, etc.) for reference purposes and for recording objective evidence collected during the audit

3.5 Conducting the Audit

3.5.1 Opening and closing meetings are not required, but may be conducted at the discretion of the QEMS Representative and the Lead Auditor taking into account expectations of Top Management.

3.5.2 The Audit Team gathers and records objective evidence by engaging in activities that may include conducting interviews with Operations Management and staff (in person, over the phone and/or through e-mail), observing operational activities and reviewing documents and records.

3.5.3 The Audit Team generates the audit findings by evaluating the objective evidence against the audit criteria (section 3.1.3). In addition to indicating conformance or non-conformance, the audit findings may also lead to the identification of opportunities for improvement (OFIs). The Lead Auditor is responsible for resolving any differences of opinion among Audit Team members with respect to the audit findings and conclusions.

3.6 Reporting the Results

3.6.1 The Lead Auditor reviews the audit findings and conclusions with the QEMS Representative and Top Management. Other audit participants may also take part in this review as appropriate. This review may take place in person (e.g., during a closing meeting) or through other means (phone call, email, etc.). Any diverging opinions regarding the audit findings and conclusions should be

	<p align="center">OPERATIONAL PLAN Wasaga Beach Well Supply System</p>	<p>QEMS Proc.: OP-19 Rev Date: 2024-11-08 Rev No: 5 Pages: 4 of 5</p>
INTERNAL QEMS AUDITS		
Reviewed by: Process & Compliance Technician	Approved by: Senior Operations Manager	

discussed and, if possible, resolved. If not resolved, this should be noted by the Lead Auditor.

3.6.2 The Lead Auditor submits a written report and/or completed work documents to the QEMS Representative. The submitted documentation must identify (at a minimum):

- Audit objectives, scope and criteria;
- Audit Team member(s) and audit participants;
- Date(s) and location(s) where audit activities were conducted;
- Audit findings including:
 - Related objective evidence for each element;
 - Any non-conformance identified referencing the requirement that was not met; and
 - OFIs or other observations.
- Audit conclusions.

3.6.3 The QEMS Representative distributes the audit results to Top Management and others as appropriate.

3.6.4 The QEMS Representative ensures that results of internal QEMS audits are included as inputs to the Management Review as per OP-20 Management Review.

3.7 Corrective Actions and Opportunities for Improvement (OFIs)

3.7.1 Corrective actions are initiated when non-conformances are identified through internal QEMS audits and are documented and monitored as per OP-21 Continual Improvement.

3.7.2 OFIs are considered, and preventive actions initiated, documented and monitored as per OP-21 Continual Improvement.

3.8 Record-Keeping

3.8.1 Internal QEMS audit records are filed by the QEMS Representative and retained as per OP-05 Document and Records Control.

4. Related Documents

- Internal Audit Records (checklists, forms, reports, etc.)
- OP-05 Document and Records Control
- OP-20 Management Review
- OP-21 Continual Improvement
- Summary Table of DWQMS Action Items - Wasaga Beach Well Supply System



OPERATIONAL PLAN
Wasaga Beach Well Supply System

QEMS Proc.: OP-19
Rev Date: 2024-11-08
Rev No: 5
Pages: 5 of 5

INTERNAL QEMS AUDITS

Reviewed by: Process & Compliance Technician

Approved by: Senior Operations Manager

5. Revision History

Date	Revision #	Reason for Revision
2008-10-21	0	Procedure issued.
2011-10-06	1	Changed “on an annual basis” to “once every 12 months’ to be more consistent with the DWQMS (CGSB OFI).
2012-04-26	2	Position Title Change: Operations Manager now Senior Operations Manager and Cluster Manager now Operations Manager.
2014-11-10	3	Removed specific names of OCWA review and approval personnel.
2018-06-21	4	Procedure updated following new template from Corporate Compliance. QP-10 procedure renamed OP-19. Removed Responsibilities and Scope sections and moved scope wording to purpose section. Added definition ‘Objective Evidence’ and modified ‘non-conformance’ definition. Replaced ‘audit evidence’ with ‘objective evidence’, and ‘conformity’ with ‘conformance’ throughout procedure. Replaced ‘once every 12 months’ with ‘once every calendar year’ (s. 3.2.1, s. 3.2.3 and s. 3.4.1) to reflect wording in DWQMS v. 2.0. Added s. 3.2.3 (and modified s. 3.4.1) to describe the frequency for auditing all DWSs covered in multi-facility Operational Plans. Changed s. 3.4.2 to include preventive actions, the results of the management review and the status/consideration of OFIs. Included wording ‘for each element’, and ‘identified referencing the requirement that was not met’ to s. 3.6.2. Moved description of process for corrective actions from QP-10 s. 5.7 and OFIs from QP-10 s. 5.8 to OP-21. Added s. 3.7 to refer to OP-21.
2024-11-08	5	Procedure updated to include under related documents: Summary Table of DWQMS Action Items - Wasaga Beach Well Supply System. Removed watermark.



OPERATIONAL PLAN
Wasaga Beach Well Supply System

QEMS Proc.: OP-20
Rev Date: 2024-08-21
Rev No: 6
Pages: 1 of 3

MANAGEMENT REVIEW

Reviewed by: Process & Compliance Technician

Approved by: Senior Operations Manager

1. Purpose

To describe the procedure for conducting a Management Review of the Quality & Environmental Management System (QEMS) at the facility level.

2. Definitions

Joint QEMS/QMS Management Review – a formal (documented) management review as per the definition below with the Town of Wasaga Beach and OCWA staff in attendance.

The Wasaga Beach Drinking Water System consists of the following: the Well Supply System and associated Treatment Systems, the two (2) elevated storage tanks, Sunnidale Booster Station and the Distribution System, with two Operating Authorities:

1. OCWA is the Operating Authority for the well supply system, treatment system, the two (2) elevated tanks and the Sunnidale Booster Station, and operates under its QEMS (Quality & Environmental Management System).
2. The Town of Wasaga Beach Public Works is the Operating Authority for the distribution system and operates under its QMS (Quality Management System).

Management Review – a formal (documented) meeting conducted at least once every calendar year by Top Management to evaluate the continuing suitability, adequacy and effectiveness of OCWA's Quality & Environmental Management System (QEMS)

Operations Management – refers to the General Manager, Senior Operations Manager and/or Operations Manager that directly oversees a facility's operations

Top Management – a person, persons or group of people at the highest management level within an operating authority that makes decisions respecting the QMS and recommendations to the owner respecting the subject system or subject systems.

OCWA has defined Top Management for the Wasaga Beach Well Supply System as:

- Operations Management – Georgian Bay Hub
- Regional Hub Manager – Georgian Highlands Region
- Safety, Process & Compliance (SPC) Manager – Georgian Highlands Region

3. Procedure

3.1 Top Management ensures that a Management Review is conducted at least once every calendar year.

In February 2012, the Town of Wasaga Beach Public Works requested that DWQMS Management Meetings become a joint meeting with the Town of Wasaga Beach and OCWA staff in attendance. The first management review was held on April 16, 2012.



OPERATIONAL PLAN
Wasaga Beach Well Supply System

QEMS Proc.: OP-20
Rev Date: 2024-08-21
Rev No: 6
Pages: 2 of 3

MANAGEMENT REVIEW

Reviewed by: Process & Compliance Technician

Approved by: Senior Operations Manager

Since 2012, the annual management review has been conducted jointly with representatives (as per s 3.2 below from both OCWA and the Town of Wasaga Beach.

- 3.2 At a minimum, the QEMS and QMS Representatives, at least one member of Top Management from OCWA and the Town of Wasaga Beach Public Works and at least one Operational Staff from OCWA must attend the Management Review meeting. Other members of Top Management may participate though their attendance is optional.
- 3.3 Other staff may be invited to attend the Management Review meeting or to assist with presenting information or in reviewing the information presented, where they offer additional expertise regarding the subject matter.
- 3.4 The standing agenda for Management Review meetings is as follows:
 - a) Incidents of regulatory non-compliance;
 - b) Incidents of adverse drinking water tests;
 - c) Deviations from critical control limits and response actions;
 - d) The effectiveness of the risk assessment process;
 - e) Internal and third-party audit results (including any preventive actions implemented to address Opportunities for Improvement (OFI) or rationale as to why OFIs were not implemented);
 - f) Results of emergency response testing (including any OFIs identified);
 - g) Operational performance;
 - h) Raw water supply and drinking water quality trends;
 - i) Follow-up on action items from previous Management Reviews;
 - j) The status of management action items identified between reviews;
 - k) Changes that could affect the QEMS;
 - l) Consumer feedback;
 - m) The resources needed to maintain the QEMS;
 - n) The results of the infrastructure review;
 - o) Operational Plan currency, content and updates;
 - p) Staff suggestions; and
 - q) Consideration of applicable Best Management Practices (BMPs).
- 3.5 In relation to standing agenda item q), applicable BMPs, if any, to address drinking water system risks discussed during other agenda items, are identified and documented in the Management Review minutes. Review and possible adoption of applicable BMPs are revisited during subsequent Management Reviews and are incorporated into preventive and/or corrective actions as per OP-21 as appropriate.
- 3.6 The OCWA QEMS Representative coordinates the Management Review and distributes the agenda with identified responsibilities to participants in advance of the Management Review meeting along with any related reference materials.
- 3.7 The Joint Management Review participants review the data presented and make recommendations and/or initiate action to address identified deficiencies as appropriate as per OP-21.



OPERATIONAL PLAN
Wasaga Beach Well Supply System

QEMS Proc.: OP-20
Rev Date: 2024-08-21
Rev No: 6
Pages: 3 of 3

MANAGEMENT REVIEW

Reviewed by: Process & Compliance Technician | Approved by: Senior Operations Manager

3.8 The OCWA QEMS Representative ensures that minutes of and actions resulting from the Management Review meeting are prepared and distributed to the appropriate OCWA Top Management and Operations personnel, and the Corporation of the Town of Wasaga Beach Public Works, specifically the Management Review attendees.

3.9 The OCWA QEMS Representative monitors the progress and documents the completion of actions resulting from the Management Review.

4. Related Documents

Management Review Reference Materials
Minutes and actions resulting from the Management Review
OP-21 Continual Improvement

5. Revision History

Date	Revision #	Reason for Revision
2008-10-21	0	Procedure issued.
2012-04-25	1	Position Title Change: Operations Manager now Senior Operations Manager and Cluster Manager now Operations Manager
2014-03-17	2	Revised as per Internal QEMS Audit of March 28, 2013 with description of the Joint QEMS/QMS Management Review.
2014-11-10	3	Removed specific names of OCWA review and approval personnel
2018-06-21	4	Procedure updated following new template from Corporate Compliance. Removed Responsibilities and Scope sections. Added definitions for Top Management and Operations Management. Revisions based on new requirements of the Standard; at least once every 12 months changed to once every calendar year (s. 3.1) and efficacy changed to effectiveness (s. 3.4). Added s. 3.2 and s. 3.3 to describe who is participating in the Management Review process. Added clarification on including any preventive actions implemented to address Opportunities for Improvement (OFI) or rationale as to why OFIs were not implemented when reviewing audit results (s. 3.4.e). Added Best Management Practices (BMPs) as a standing agenda item (s. 3.4.q). Added s. 3.5 to include consideration of BMPs and link OP-20 to OP-21 Continual Improvement.
2021-10-13	5	Revised section 3.2 to alter required attendees for the Town of Wasaga Beach to better align with their Operational Plan requirements.
2024-08-21	6	Procedure updated to provide clarification on the Joint Management review, OCWA QEMS rep responsibilities. Definitions updated and Operations Management – updated from North Simcoe Hub to Georgian Bay Hub. Removed Watermark.



OPERATIONAL PLAN

Wasaga Beach Well Supply System

QEMS Proc.: OP-21
Rev Date: 2024-11-08
Rev No: 2
Pages: 1 of 4

CONTINUAL IMPROVEMENT

Reviewed by: Process & Compliance Technician

Approved by: Senior Operations Manager

1. Purpose

To describe the procedure for tracking and measuring continual improvement of the Quality & Environmental Management System (QEMS) for the Wasaga Beach Well Supply System.

2. Definitions

Continual Improvement - recurring activity to enhance performance (ISO 14001:2014)

Corrective Action – action to eliminate the cause of detected nonconformity of the QMS with the requirements of the DWQMS or other undesirable situation

Non-conformance – the non-fulfilment of a DWQMS requirement

Preventive Action – action to prevent the occurrence of nonconformity of the QMS with the requirements of the DWQMS or other undesirable situation

3. Procedure

3.1 OCWA strives to continually improve the effectiveness of its QEMS for this drinking water system(s) through the identification and implementation of corrective/preventive actions and, as appropriate, through review and consideration of applicable Best Management Practices (BMPs).

3.2 Corrective Actions

3.2.1 Non-conformances may be identified through an internal or external QEMS audit(s) conducted for this drinking water system. They may also be identified as a result of other events such as:

- an incident/emergency;
- community/Owner complaint;
- other reviews; and
- operational checks, inspections or audits.

3.2.2 The QEMS Representative (in consultation with Operations Management and/or the SPC Manager) investigates the need for a corrective action to eliminate the root cause(s) so as to prevent the non-conformance from recurring. The investigation may also include input from the operators and other stakeholders and the consideration of BMPs as appropriate.

3.2.3 The QEMS Representative determines the corrective action needed based on this consultation. The Operations Management (or designate) assigns responsibility and a target date for resolution.

	<p align="center">OPERATIONAL PLAN Wasaga Beach Well Supply System</p>	<p>QEMS Proc.: OP-21 Rev Date: 2024-11-08 Rev No: 2 Pages: 2 of 4</p>
CONTINUAL IMPROVEMENT		
Reviewed by: Process & Compliance Technician	Approved by: Senior Operations Manager	

3.2.4 The QEMS Representative ensures corrective actions are documented using the “Summary Table of DWQMS Action Items- Wasaga Beach Well Supply System” table. The QEMS Representative monitors the progress of corrective action(s) and provides status updates to Top Management.

3.2.5 The implementation and effectiveness of corrective actions are verified during subsequent internal QEMS audits and are considered during the Management Review. If there is evidence that the action taken was not effective, the Operations Management (or designate) initiates further corrective action and assigns resources as appropriate until the non-conformance is fully resolved.

3.3 Preventive Actions

3.3.1 Potential preventive actions may be identified through an internal or external QEMS audit as Opportunities For Improvement (OFIs), during the Management Review or through other means such as:

- staff/Owner suggestions;
- regulator observations;
- evaluation of incidents/emergency response/tests;
- the analysis of facility/Regional Hub or OCWA-wide data/trends;
- non-conformances identified at other drinking water systems; or
- a result of considering a BMP.

3.3.2 The QEMS Representative (in consultation with Operations Management and/or the SPC Manager) considers whether a preventive action is necessary. The review may also include input from the operators and other stakeholders and the consideration of BMPs as appropriate.

3.3.3 If it is decided that a preventive action is necessary, the QEMS Representative determines the action to be taken based on this consultation and the Operations Management (or designate) assigns responsibility and a target date for implementation.

3.3.4 The implementation of preventive actions is tracked by the QEMS Representative using the “Summary Table of DWQMS Action Items- Wasaga Beach Well Supply System” table.

3.3.5 The implementation and effectiveness of preventive actions are verified during subsequent internal QEMS audits and are considered during the Management Review. If there is evidence that the action taken was not effective, the Operations Management (or designate) may consider further preventive actions and assigns resources as appropriate.

	<p align="center">OPERATIONAL PLAN Wasaga Beach Well Supply System</p>	<p>QEMS Proc.: OP-21 Rev Date: 2024-11-08 Rev No: 2 Pages: 3 of 4</p>
CONTINUAL IMPROVEMENT		
Reviewed by: Process & Compliance Technician	Approved by: Senior Operations Manager	

3.4 The QEMS Representative and Operations Management monitor corrective/preventive actions on an ongoing basis and review the status and effectiveness of the actions during subsequent Joint Management Review meetings.

3.5 Best Management Practices (BMPs)

3.5.1 The QEMS Representative and/or Operations Management in consultation with the SPC Manager will review and consider applicable internal and/or external BMPs identified by internal and/or external sources as part of the Management Review (OP-20) and in the corrective and preventive action processes described above.

3.5.2 BMPs may include, but are not limited to:

- Facility/Regional Hub practices developed and adopted as a result of changes to legislative or regulatory requirements, trends from audit findings or drinking water system performance trends;
- OCWA-wide BMPs/guidance or recommended actions;
- Drinking water industry based standards/BMPs or recommendations; or
- Those published by the Ministry

3.5.3 At a minimum, applicable BMPs must be reviewed and considered once every 36 months.

4. Related Documents

OP-05 Document and Records Control
 OP-20 Management Review
 Management Review Minutes
 Internal Audit Records
 External Audit Records
 Summary Table of DWQMS Action Items- Wasaga Beach Well Supply System



OPERATIONAL PLAN
Wasaga Beach Well Supply System

QEMS Proc.: OP-21
Rev Date: 2024-11-08
Rev No: 2
Pages: 4 of 4

CONTINUAL IMPROVEMENT

Reviewed by: Process & Compliance Technician | Approved by: Senior Operations Manager

5. Revision History

Date	Revision #	Reason for Revision
2018-06-21	0	Procedure issued – Information within OP-21 was originally set out in the Main Body of OCWA’s Operational Plan (last revision 7 dated 2016-06-22). Information from QP-10 Internal Audit (s. 5.7 and s. 5.8) was incorporated into s. 3.2 and s. 3.3 of OP-21 but was modified to address non-conformances identified from additional inputs other than internal audits and preventive actions resulting from means other than OFIs from internal audits. In addition R&Rs were revised to include the SPC Manager, and to clarify the role of the QEMS Representative in investigating and determining corrective and preventive actions needed. A section on Best Management Practices (s. 3.5) was added to meet the new requirements of DWQMS v. 2.0.
2023-01-23	1	Replaced the “Implementation Action Plan” form/table wording with the “Summary Table of DWQMS Action Items- Wasaga Beach” table as this is used for tracking action items related to the Wasaga Beach Well Supply System DWQMS Action items, as per the 2022 Internal Audit Recommendation.
2024-11-08	2	Procedure updated, rewording the action items table to “Summary Table of DWQMS Action Items- Wasaga Beach Well Supply System”. Updated MECP reference to Ministry. Removed watermark.

Schedule C – Director’s Directions for Operational Plans (Subject System Description Form) Municipal Residential Drinking Water System

Fields marked with an asterisk (*) are mandatory.

Owner of Municipal Residential Drinking Water System *
The Corporation of the Town of Wasaga Beach

Subject Systems

Name of Drinking Water System (DWS) *	Licence Number *	Name of Operating Subsystems (if applicable)	Name of Operating Authority *	DWS Number(s) *
1. Wasaga Beach Drinking Water System	131-101	Wasaga Beach Well Supply, Wasaga Beach Distribution System	Ontario Clean Water Agency, The Town of Wasaga Beach	220002137

Contact Information for Questions Regarding the Operational Plan

Primary Contact

Last Name *	First Name *	Middle Initial
Tilotta	Kristen	
Title *	Telephone Number *	Email Address *
Manager, Safety, Process & Compliance (A)	705-441-5823 ext.	KTilotta@ocwa.com

Secondary Contact

Last Name	First Name	Middle Initial
Kasperavicius	Colin	G.R
Title	Telephone Number	Email Address
Senior Operations Manager	705-623-2390 ext.	CKasperavicius@ocwa.com